

The information presented in this publication has been carefully checked for reliability; however, no responsibility is assumed for inaccuracies. Specifications are subject to change without notice.

Trademarks

IBM, PC/AT, PC/XT, PS/2, and OS/2 are trademarks of International Business Machines Corporation.

Intel and Pentium® II are trademarks of Intel Corporation.

AMI is a trademark of American Megatrends Inc.

MS-DOS and WINDOWS 95/98/NT, Direct Sound 3D, Direct Music are registered trademarks of Microsoft Corporation.

A3D is a trademark of Aureal Inc.

Sound Blaster and SB-Link are trademarks of Creative Technology Ltd.

PC-cillin and ChipAwayVirus are trademarks of Trend Micro, Inc.

Copyright (C) 1998.
All Rights Reserved.
M750, Version 1.2
I6dX/December, 1998

Contents

| | |
|--|----------|
| Chapter 1: Introduction | 1 |
| Key Features | 2 |
| Unpacking the Mainboard & Static Electricity Precautions..... | 5 |
| Chapter 2: Hardware Configuration | 6 |
| Mainboard Component Locations | 7 |
| CPU Installation | 8 |
| Installation Procedures..... | 9 |
| CPU Speed Setting..... | 10 |
| J7 – APIC Slot..... | 11 |
| Memory Installation..... | 11 |
| Jumper Settings | 12 |
| JP4 – CMOS RAM Clear Selector | 12 |
| ATX Functions & Connectors..... | 13 |
| PW1 – ATX Power Connector | 13 |
| J6 (21, 22) – Power Button and Suspend Switch Connector | 13 |
| Alarm Wake Up | 14 |
| LAN/Modem Ring Wake-On..... | 14 |
| J4 – LAN Wake-On Connector | 15 |
| Keyboard Power-On..... | 15 |
| JP5 – Keyboard Power On Selector | 16 |
| Connectors..... | 16 |
| COM2 – Serial Port #2..... | 17 |
| FDC1 – Floppy Disk Drive Connector | 17 |
| IDE1/IDE2 – Primary/Secondary IDE Connectors | 17 |
| External Connectors Location..... | 17 |
| FAN 1, FAN 2 – CPU Fan Power Connectors | 18 |
| SB1 – SB Link Connector | 18 |
| IR – Infrared Connector | 19 |
| Case Connectors: J6..... | 19 |
| J6 (2, 4, 6, 8, 10) – Keylock & Power LED Connector .. | 20 |
| J6 (1, 3, 5, 7) – Speaker Connector | 20 |
| J6 (13, 14) – Turbo LED Connector | 20 |
| J6 (15, 16) – HDD LED Connector..... | 20 |
| J6 (17, 18) – Reset Switch Connector..... | 20 |
| Onboard Sound Pro | 21 |
| Sound and Game (on the External Connectors) | 21 |
| CD1/CD2 – Analog Audio from CD-ROM..... | 22 |
| J1 – Digital Audio Connectors | 23 |

| | |
|--|-----------|
| JP2 – SPDIF OUT Signal Level Selector..... | 23 |
| JP6 – Internal SPDIF IN Connector | 23 |
| Notice for PCI Sound Pro Application..... | 24 |
| The Four Speakers System | 25 |
| Chapter 3: BIOS Setup | 27 |
| Entering BIOS Setup | 28 |
| Default | 28 |
| Load Optimal Settings | 28 |
| Load Best Performance Settings | 29 |
| Setup Items..... | 29 |
| Standard CMOS Setup | 29 |
| Advanced CMOS Setup | 30 |
| Advanced Chipset Setup | 33 |
| Power Management Setup..... | 35 |
| PCI/Plug and Play Setup..... | 37 |
| Peripheral Setup..... | 39 |
| H/W Monitor & CPU PnP Setup | 40 |
| Change Supervisor Password | 41 |
| Auto-Detect Hard Disks..... | 41 |
| Save Settings and Exit | 41 |
| Exit Without Saving..... | 41 |
| Chapter 4: SoftWare Driver | 42 |

Chapter 1

Introduction

This mainboard is an **Intel 440BX 100MHz** highly integrated high-performance mainboard which supports **Dual** Pentium® II microprocessor and provides CPU Plug and Play feature for faster and easier CPU installation. The mainboard features highly flexible configurations and is fully IBM PC/AT compatible.

The mainboard uses a high-end AGPset chipset that supports the PCI/ISA and Green standards, provides the Host/AGP bridge, and integrates all system control functions such as ACPI(Advanced Configuration and Power Interface). The **ACPI** provides more energy saving features for the OSPM(OS Direct Power Management) function.

The mainboard has a built-in **i740 AGP Graphics Accelerator** with 8MB frame buffer and an onboard 3D **PCI Sound Pro** to meet PC98' specifications for 3D Multimedia systems, and built-in **Hardware Monitor** circuit to monitor CPU/Chasis temperatures/fan speeds/voltages with AMI **Desktop Client Manager** and options to support Intel LANDesk Client Manager(**LDCM**). And the mainboard BIOS provides Trend's ChipAwayVirus to ensure the entire boot process virus free.

Key Features

The advanced features of the mainboard include:

- ❑ Intel 440BX AGP chipset:
 - supports **dual** Pentium® II 233~**500MHz** and single Celeron 266~**433MHz** CPUs
 - supports upgradable I/O APIC module to operate dual Pentium II processor
 - supports 66.6MHz and **100MHz** FSB (Front Side Bus)
 - provides CPU Plug and Play feature for faster and easier CPU installation

- ❑ Memory:
 - provides 3 DIMMs for 3.3V SDRAM memory modules
 - supports a maximum size of 768MB system memory
 - supports ECC (1-bit Error Code Correct) function

- ❑ Expansion slots:
 - provides 4 PCI, and 3 ISA slots;

- ❑ Onboard 2 IDE ports:
 - supports 4 IDE devices maximum
 - supports PIO, PCI Bus Master and Ultra DMA/33/66 operation modes

- ❑ ATX Power Supply:
 - provides ATX power connectors and features of ATX power
 - provide Power Button/Suspend Switch and **Keyboard Power On/Off** (needs Win98 keyboard) functions
 - Alarm Wake Up, LAN/Modem Wake Up functions

- ❑ Onboard DC-DC Step Down Regulator:
 - complies with Intel VRM V8.2 specification
 - Over-Voltage and Over-Current protection

- ❑ Onboard **Intel i740 AGP Graphics Accelerator**:
 - supports AGP Ver 1.0 specification and 66/133MHz
 - provides **8MB** frame buffer
 - high resolution graphic modes up to 1600 x 1200

- ❑ Onboard **3D PCI Sound Pro** Features:
 - meets PC98' specifications
 - full Duplex playback and recording, built-in 16-bit CODEC with filters
 - HRTF 3D Positional Audio technology: supports both Direct Sound 3D[®] & A3D[®] interfaces and **4 channel speakers mode**
 - supports Windows 3.1/95/98 and Windows NT4.0
 - built-in 32 ohm earphone buffer and 3D surround
 - supports MPU-401 Game/MIDI port and legacy audio SB16
 - downloadable Wave-Table Synthesizer supports Direct Music[®]
 - Digital Audio Interface (**SPDIF**) In/Out up to **24-bit** stereo 44KHz sampling rate voice and measured **120dB** audio quality
 - Stereo Mixer supports analog mixing from CD-Audio, Line-In, and digital mixing from voice, FM/Wave-Table and digital CD-Audio

- ❑ Onboard Multi-I/O and Peripheral interface, including:
 - 1 floppy port with 1 Mb/s transferring rate
 - 2 serial ports with 16550 compatible with Fast UART
 - 1 parallel port with EPP and ECP capabilities
 - 2 USB ports and PS/2 keyboard/mouse ports
 - 1 IR interface

- ❑ Built-in Hardware Monitor circuit:
 - detects CPU temperature, fan speed, and current voltages
 - supports Intel LANDesk Client Manager (LDCM)

- ❑ BIOS:
 - Onboard **2M Flash ROM** supports complete ACPI and Legacy PMU and is fully compatible with PC97 and PC98
 - provides Plug & Play function which detects the peripheral devices and expansion cards automatically
 - supports Trend's **ChipAwayVirus** option to ensure the entire boot process is virus free, no installation and configuration worries

- ❑ Bundled:
 - AMI **Desktop Client Manager** detects abnormal condition and thermal management through the network link or self care
 - **PC-cillin98** (OEM) provides automatic virus protection for Windows 95/98 and the Internet

- ❑ Dimension:
 - ATX Form Factor, 30.5CM (L) x 22CM (W)

Unpacking the Mainboard & Static Electricity Precautions

This Mainboard package contains the following items:

1. This Mainboard and the Device Driver
2. The Slot1 holder and AT cables
3. This User's Guide
4. SPDIF/IN cable
5. COM2 & Digital Audio ribbon cables/bracket

The mainboard is easily damaged by static electricity. Follow the precautions below while unpacking or installing the mainboard.

1. Do not remove the mainboard from its original package until you are ready to install it.
2. Frequently ground yourself to discharge any static electric charge that may build up in your body while working on installation and/or configuration. For example, you may ground yourself by grasping an unpainted portion of the system's metal chassis.
3. Remove the mainboard from its anti-static packaging and place it on a grounded surface, component side up.
4. Handle the mainboard by its edges or by the mounting bracket to avoid touching its components.
5. Check the mainboard for damage. If any integrated circuit appears loose, press carefully to seat it firmly in its socket.
6. Do not apply power if the mainboard appears damaged. If there is damage to the board contact your dealer immediately.

Chapter 2

Hardware Configuration

Before you install the mainboard into the system chassis, you may find it convenient to first configure the mainboard's hardware. This chapter describes how to set jumpers and install memory modules, and where to attach components, however, the CMOS jumper is set on the "Clear" position when this mainboard is shipped and you need to set it to the "Normal" position in order for the mainboard perform properly.

Warning: *Set JP4 to "Normal" position before setting other jumpers or memory modules. This mainboard will not function properly if you fail to do so.*

Mainboard Component Locations

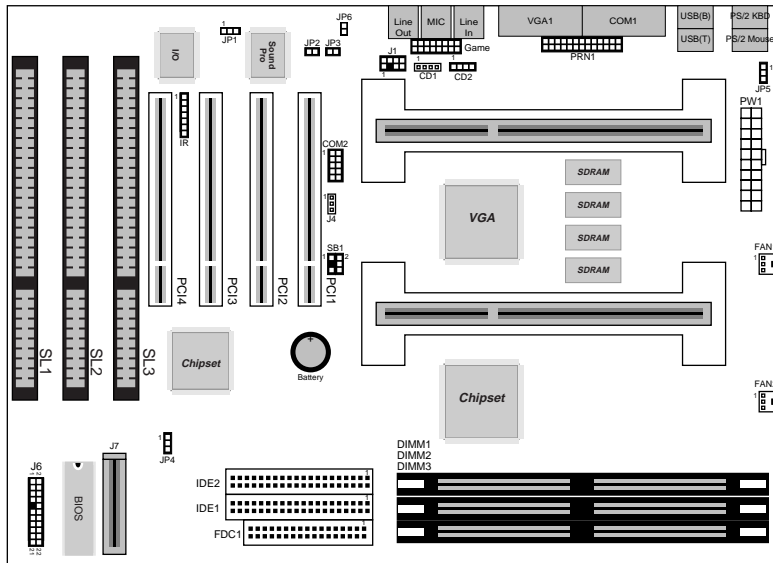
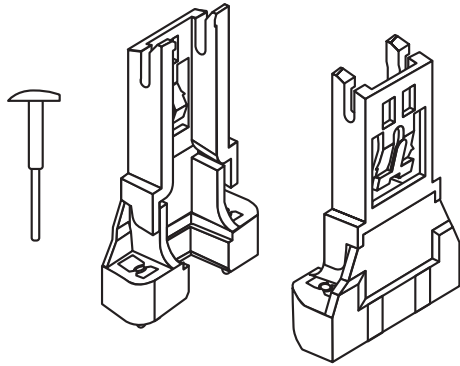

Figure 2-1. Mainboard Component Locations

CPU Installation

This mainboard supports 2 Intel Pentium® II CPU by 2 Single Edge Contact (SEC) slots and a retention clip set which is fit for 3 different mechanical types of Intel CPU (SEPP, SECC, and SECC2). The following drawing shows the retention clip set. It has been preinstalled before shipping to make the CPU installation easier for users. However, there are still a few more steps needed to complete the CPU installation, please refer to the following procedures.



Installation Procedures

Follow the following steps in order to install your Intel Pentium® II properly.

Step 1:

Make sure that the mainboard is set the same direction as the following drawing before doing any installation, and, notice that J5 Slot1 must be installed first as shown in the following drawing.

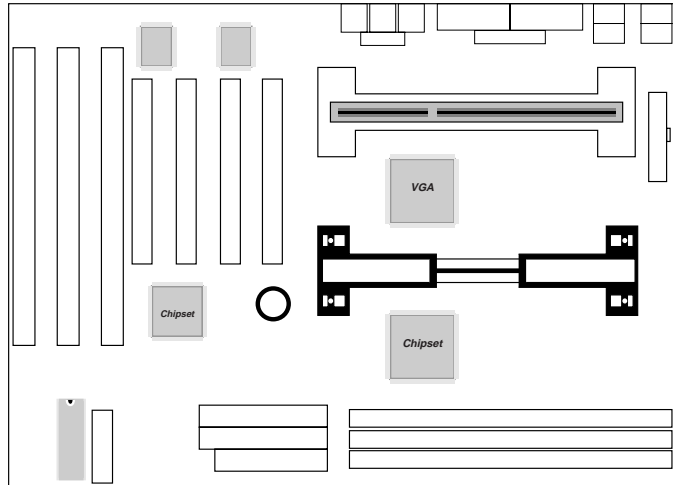

Step 2:

There is one set of the Slot1 Holder retention that was installed on your motherboard, and the two chutes of Holder retention are screwed in. Lift up both of the Holder chutes as shown in the following drawing.

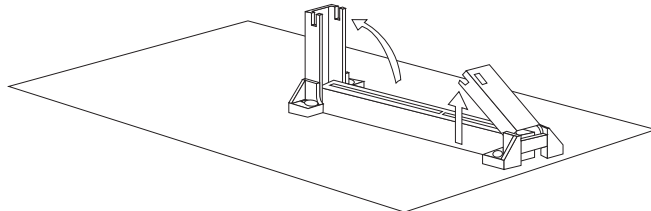

Step 3:

Flatten the two latches on the side of CPU. Insert the CPU into the Holder retention. Lock the two latches to secure the CPU.

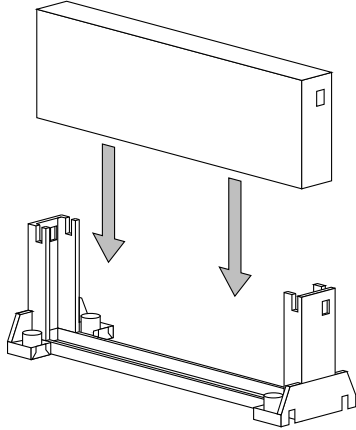
**CPU Speed Setting**

This mainboard provides CPU Plug and Play technology, so that there is no need to do the CPU jumper setting. Enter the BIOS Setup and select “CPU Plug and Play Setup”. Choose the correct CPU speed to match your CPU installed.

However, if you need to change a CPU, follow the below steps:

1. Power off system and unplug the power core.
2. Install a new CPU to Slot1.
3. Clear CMOS RAM (see Jumper Settings) or hold down the <Page Up> key and then power on the system.
4. After power on the system, then enter the BIOS Setup section to set the new CPU speed.

Note: If the CPU speed is set incorrectly and fails to boot up the system, then repeat steps 1, 3, 4 again.

J7 – APIC Slot

While using Dual CPUs, you must insert APIC module into APIC Slot and repeat the above Step 2 and 3 again to install another CPU.

Memory Installation

The mainboard lets you add up to 768MB of system memory through 3 DIMM sockets on the board, that is divided into 3 banks: Bank 0, Bank 1, and Bank 2, which supports the following memory configurations.

| Bank | Memory Module |
|--|--|
| Bank 0 DIMM1 | 4MB, 8MB, 16MB, 32MB, 64MB, 128MB, 256MB |
| Bank 1 DIMM2 | 4MB, 8MB, 16MB, 32MB, 64MB, 128MB, 256MB |
| Bank 2 DIMM3 | 4MB, 8MB, 16MB, 32MB, 64MB, 128MB, 256MB |
| Total System Memory = Bank 0 + Bank 1 + Bank 2 | |

- Notes:
1. The speed of SDRAM DIMM modules have to be faster than 12ns (“-12”parts), while 100MHz clock speed used, the speed of SDRAM DIMM should meet the PC100 SDRAM specification (8ns or “-8” SDRAM at least).
 2. Supports only 3.3V SDRAM DIMM modules.

Jumper Settings

JP4 – CMOS RAM Clear Selector

The battery on this mainboard is designed to retain the system configuration in CMOS RAM. In order to save the life of the battery, this jumper is set to “Clear CMOS” position when this board is shipped, therefore, you need to set this jumper to “Normal” position before setting other jumpers or memory modules.

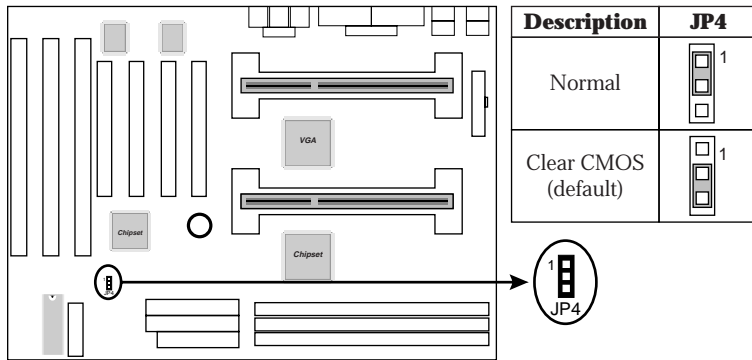

- Note:*
- 1. This jumper needs to be set on Normal Mode before using.*
 - 2. Turn off the system and unplug the power core when you need to clear the CMOS.*

ATX Functions & Connectors

This mainboard supports ATX power and ACPI specification. The ATX functions and connectors are described below.

PW1 – ATX Power Connector

The ATX power supply is a single 20-pin connector. Connect the ATX power supply to this connector which provides all power for the mainboard.

| Pin | Description | Pin | Description | Pin | Description | Pin | Description |
|-----|-------------|-----|-------------|-----|-------------|-----|-------------|
| 1 | 3.3V | 6 | +5V | 11 | 3.3V | 16 | Ground |
| 2 | 3.3V | 7 | Ground | 12 | -12V | 17 | Ground |
| 3 | Ground | 8 | Power OK | 13 | Ground | 18 | -5V |
| 4 | +5V | 9 | 5VSB | 14 | PS-ON | 19 | +5V |
| 5 | Ground | 10 | +12V | 15 | Ground | 20 | +5V |

J6 (21, 22) – Power Button and Suspend Switch Connector

Attach the ATX Power Button cable to this connector. This connector will be not only an ATX power button but a Suspend switch as well. Details are described below:

Turn the system back on by pushing the power button, and, if the system is already on, pushing the power button allows the system to be switched to the Suspend mode. However, if push and hold the power button for more than 4 seconds, then the system will be turned off completely.

And, if the system is already in the Suspend mode, pushing the power button rapidly will turn on the system.

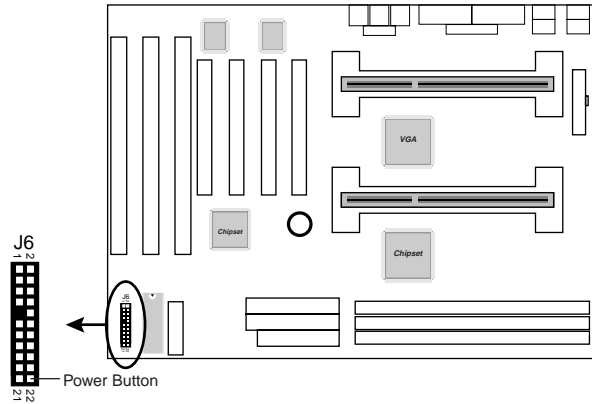

Alarm Wake Up

If you want to autoboot the system at a certain time, set the function of RTC Alarm time properly and the function of RTC Alarm Power On option in the BIOS Setup section will be set to "Enabled."

LAN/Modem Ring Wake-On

While in Soft-off/Suspend state, if an external LAN/modem ring-up signal occurs, the system wakes up and can be remotely accessed. Make sure that the Serial Port2 option in the Power Management Setup of the BIOS Setup section is set to "Monitor" and the LAN Card Pwoer On option is set to "Enabled".

User must connect LAN card to the following connector when using LAN Wake-On function.

J4 – LAN Wake-On Connector

Connect this connector to the LAN card which supports ACPI spec.

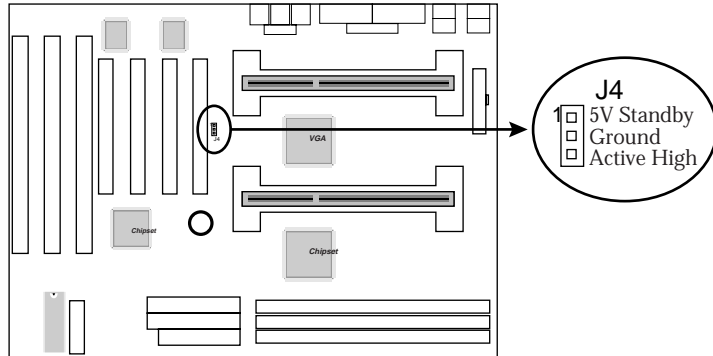

Keyboard Power-On

Press the hot key to power on the system when the Keyboard Power On option is set to “Enabled” in the Power Management Setup, and also, you need to choose “Hot Key” in the Stroke Keys Selected option under the Keyboard Power On option, and set the following jumper. If the keyboard that supports Win98 Power On function, you need to set ACPI Wakeup to the Stroke Keys Selected option.

JP5 – Keyboard Power On Selector

This jumper is designed for the user to turn on the system by using the keyboard.

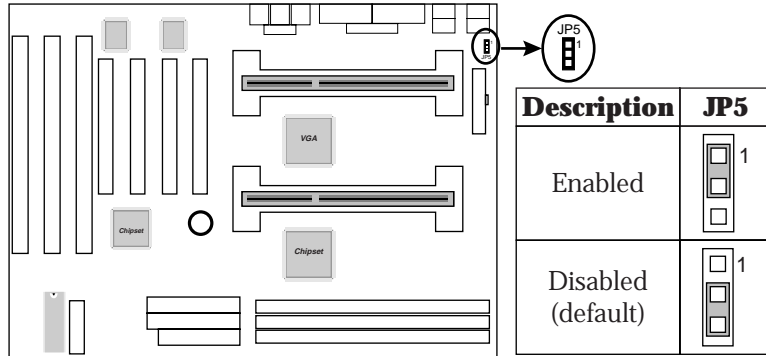

Note: Make sure that the system power can provide 720mA on +5VSB(+5V Standby) signal before using Keyboard Power On function.

Connectors

Attach system components and case devices to the mainboard via the mainboard connectors. A description of each connector pins follows. See Figure 2-1 for the location of the connectors on the mainboard.

Note: Make sure that the power is turned off before making any connection to the board.

COM2 – Serial Port #2

FDC1 – Floppy Disk Drive Connector

**IDE1/IDE2 – Primary/Secondary IDE
Connectors**

External Connectors Location

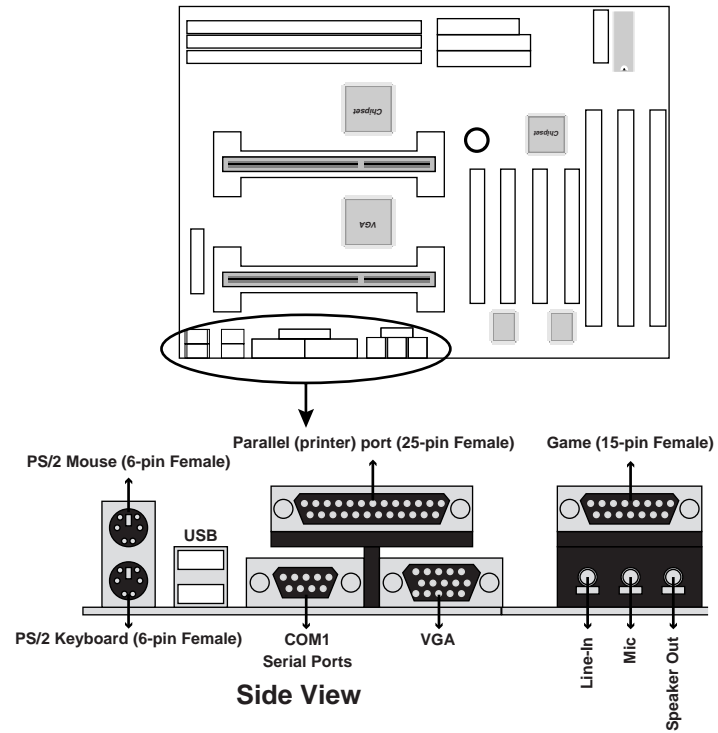

FAN 1, FAN 2 – CPU Fan Power Connectors

Connect CPU/System fan cables to FAN 1/FAN 2. See the following drawing for the locations on the mainboard.

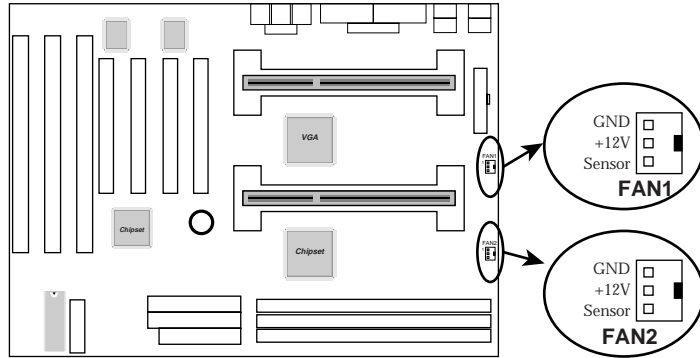

SB1 – SB Link Connector

Uses Intel PC-PCI technology to deliver Sound Blaster 16 compatibility to PCI Sound Card, i.e., AWE64D, to enable users to play read mode DOS games.

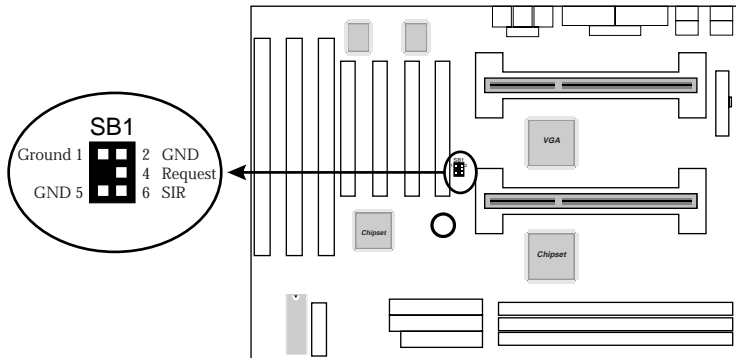

IR – Infrared Connector

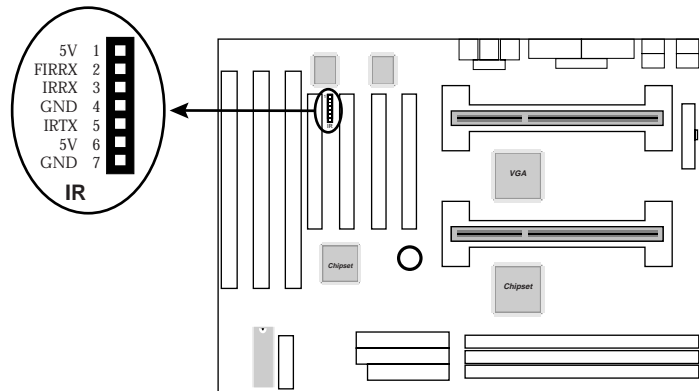

Case Connectors: J6

This connector contains: Speaker, Power LED, Keylock, Turbo LED, HDD LED, Reset Switch, and Power Button. Refer to the following drawing for the location on the mainboard.

- pin1, 3, 5, 7 – Speaker
 - pin2, 4, 6 – Power LED
 - pin8, 10 – Keylock
 - pin13, 14 – Turbo LED
 - pin15, 16 – HDD LED
 - pin17, 18 – Reset Switch
 - pin21, 22 – Power Button
- (refer to ATX Functions & Connectors section)*

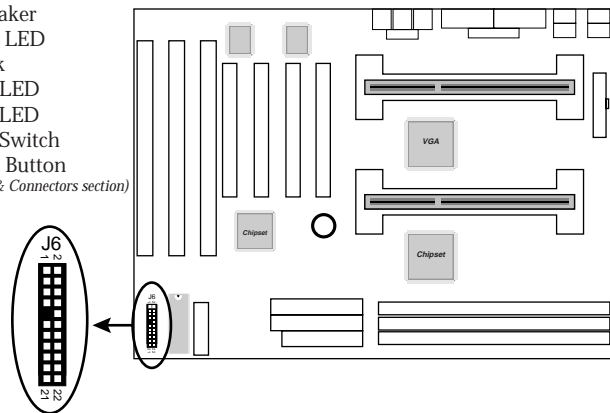

J6 (2, 4, 6, 8, 10) – Keylock & Power LED Connector

Keylock connector enables and disables the keyboard key-in function on the case.

| Pin | Description |
|-----|-------------|
| 2 | LED Output |
| 4 | N.C. |
| 6 | Ground |
| 8 | Keylock |
| 10 | Ground |

J6 (1, 3, 5, 7) – Speaker Connector

| Pin | Description |
|-----|-------------|
| 1 | Data Out |
| 3 | N.C. |
| 5 | Ground |
| 7 | +5V |

J6 (13, 14) – Turbo LED Connector

| Pin | Description |
|--------|-------------|
| 13 (+) | Anode |
| 14 (-) | Ground |

J6 (15, 16) – HDD LED Connector

| Pin | Description |
|--------|-------------|
| 15 (+) | +5V |
| 16 (-) | Active Low |

J6 (17, 18) – Reset Switch Connector

| Setting | Description |
|---------|--------------|
| Open | Normal Mode |
| Close | Reset System |

Onboard Sound Pro

Sound and Game (on the External Connectors)

This connector provides Line-IN/Rear, MIC (Microphone), Line-Out (Speaker) signals for audio I/O, and Game Port (which is also used as the Joystick/MIDI port) signals.

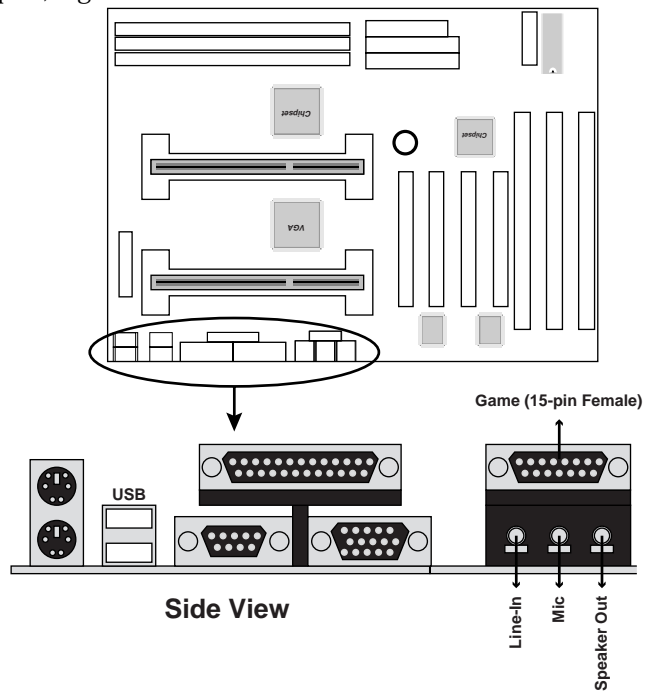

CD1/CD2 – Analog Audio from CD-ROM

Connect from “AUDIO” output of the CD-ROM driver to these connectors. For Panasonic or compatible type of CD-ROM, connect to CD1 (pin signals assignment is G-L-G-R), and for Sony or compatible type of CD-ROM, connect to CD2 (pin signals assignment is L-G-G-R).

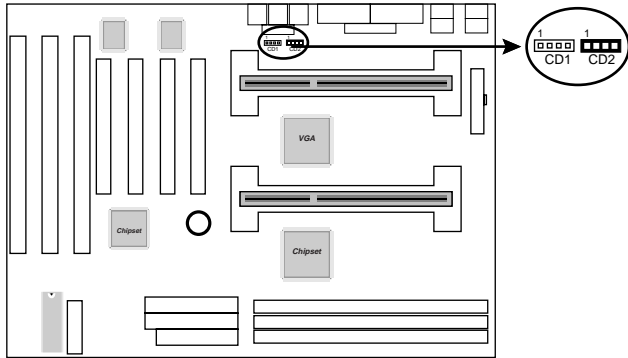

J1 – Digital Audio Connectors

Connect this connector to the Digital Audio ribbon cable/bracket that contains 3 jacks for Aux IN, SPDIF IN, and SPDIF OUT devices. Aux IN is also called the second Line-in. Connect SPDIF IN to the Mini-Disk to record. Notice that you should avoid using this jack simultaneously with the internal SPDIF IN connector. Connect SPDIF OUT to the AC3 Audio Amplifier or Mini-Disk to play, and set the following jumper to select 5V or 0.5V signal level for the used device.

JP2 – SPDIF OUT Signal Level Selector

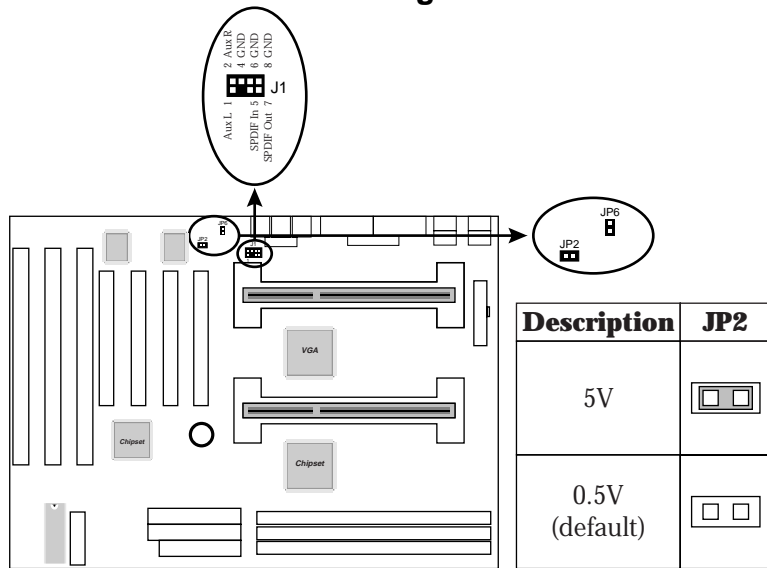

JP6 – Internal SPDIF IN Connector

Connect to “DIGITAL AUDIO” port of the CD-ROM drive by using the SPDIF/IN cable, which gives you the non-distortion digital audio from CD-ROM. Avoid using this connector simultaneously with the SPDIF IN jack.

Notice for PCI Sound Pro Application

1. Before you install the PCI Sound Pro drivers, make sure your Operating System has been installed, otherwise the PCI Sound Pro might be detected as "Other Device" by the device manager of your OS.
2. After the drivers are properly installed, choose MULTIMEDIA icon in the CONTROL PANEL when you need to use the Software Wave-Table drivers as a MIDI output device. Select the MIDI page, and click on "C-media SoftMidi Synthesis (Win98)/Driver (Win95)", then click "OK" to confirm.
3. A Windows application named Audio Rack is provided within the PCI Sound Pro drivers, which gives you control over all the audio functions through a user interface, which is just as simple to operate as a home stereo system. We recommend you to use the System Mixer within Audio Rack to control the volume, the recording device, and the recording gain.
4. If the devices that you are using uses the MIDI port as the control interface, you need to select MULTIMEDIA icon within the CONTROL PANEL. Select the MIDI page, and click on "CM8338 MPU-401" (Win98) or "CM8338/C3DX PCI Audio External MIDI port" (Win95), then click "OK" to confirm.
5. For more information, refer to the PCI Sound Pro manual in the CD which comes with this mainboard.

The Four Speakers System

Onboard Sound Pro provides 2 wave channels (front/rear), known as the 4 speakers system. When application programs via DirectSound[®] 3D or A3D[®] interface locate the sound sources to the listener's back, the two rear speakers will work to enhance the rear audio positional effect, so as to complement the insufficiency of using only two front speakers to emulate the audio effect. The following is the hardware installation and the software setups:

1. Speaker Installation

Connect the front pair speakers to the Line-out jack on the Sound port, and then, connect rear pair speakers to Line-in/Rear jack. The original Line-in can be moved to Aux-in.

2. Speaker Position

Set up your speakers similar to the following figure to get the best audio result.

3. Mixer Setup

There is a 4 speakers option in the Volume Control of the Mixer when you are setting up the PCI Audio Application. Click on the 4 SPK icon to enable this option. This means that the rear speakers are connected to Line-in/Rear jack. However, in order to avoid hardware conflicts, **DO NOT** enable this option when Line-in/Rear jack is connected to other external Line-in sources. Turn on/off the output of the front speakers and adjust the volume of speakers to the same volume for the rear speaker.

4. Demo

Execute the "Helicopter" demo within the C3D HRTF Positional Audio Demos of the PCI Audio Application. When the helicopter flies behind you, it means that the rear speakers are working properly.

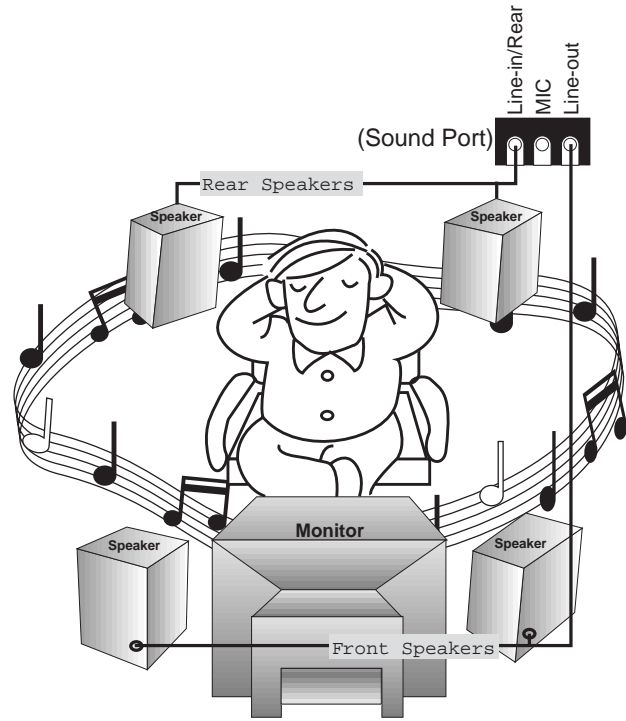

Set Up of 4 Speakers

Chapter 3

BIOS Setup

This chapter explains how to configure the mainboard's BIOS setup program. The setup program provided with the mainboard is the BIOS from AMI.

After you have configured the mainboard and have assembled the components, turn on the computer and run the software setup to ensure that the system information is correct.

The software setup of the system board is achieved through Basic Input-Output System (BIOS) programming. You use the BIOS setup program to tell the operating system what type of devices are connected to your system board.

The system setup is also called CMOS setup. Normally, you need to run system setup if either the hardware is not identical with information contained in the CMOS RAM, or if the CMOS RAM has lost power.

Note: Hold down the <End> key then power on to reboot the system when installing newer BIOS into this mainboard .

Entering BIOS Setup

To enter the BIOS Setup program:

1. Turn on or reboot the system. A screen appears with a series of diagnostic checks.
2. When “Hit if you want to run SETUP” appears, press the key to enter the BIOS setup program. The following screen appears:

| AMIBIOS SIMPLE SETUP UTILITY - VERSION 1.1X (C)1998 American megatrends, Inc. All Rights Reserved | |
|---|-----------------------------|
| Standard CMOS Setup | Peripheral Setup |
| Advanced CMOS Setup | H/W Monitor & CPU PnP Setup |
| Advanced Chipset Setup | Change Supervisor Password |
| Power Management Setup | Auto-Detect Hard Disks |
| PCI/Plug and Play Setup | Save Settings and Exit |
| Load Optimal Settings | Exit Without Saving |
| Load Best Performance Settings | |
| Esc: Quit ↑ ↓ → ←: Select Item (Shift) F2: Change Color F5: Old Values F6: Optimal values F7: Best performance values F10 : Save&Exit | |
| Standard CMOS setup for changing time, date, hard disk type, etc. | |

3. Use your keyboard to choose options. Modify system parameters to reflect system options. Press Alt-H for Help.

Default

Every option in the BIOS Setup contains two default values: Best default and the Optimal default value.

Load Optimal Settings

The Optimal default values provide optimum system settings for all devices and system features.

Load Best Performance Settings

The Best default values provide best performance settings for all devices and system features, however depending on the devices used, these settings are not recommend for long hours of work load.

Setup Items

Standard CMOS Setup

Choosing the item from the BIOS Setup main menu. All Standard Setup options are described in this section.

```

AMIBIOS SETUP - STANDARD CMOS SETUP
(C)1998 American Megatrends, Inc. All Rights Reserved

Date (mm:dd:yy) : Sat Oct 17, 1998
Time (hh:mm:ss) : 00:32:28

          TYPE          SIZE Cyln  Head  WPcom  Sec  LBA  Blk  PIO  32Bit
Pri Master : Not Installed
Pri Slave  : Not Installed
Sec Master : Not Installed
Sec Slave  : Not Installed

Floppy Drive A : Not Installed
Floppy Drive B : Not Installed

          Base Memory : 0 Kb
          Other Memory : 384 Kb
          Extended Memory : 0 Mb
          Total Memory : 1 Mb

Month: Jan - Dec
Day: 01 - 31
Year: 1901 - 2099

ESC : Exit
↑↓ : Select Item
PU/PD/+/- : Modify
(Shift)F2 : Color
    
```

Date/Time

Select the Date/Time option to change the date or time. The current date and time are displayed. Enter new values through the displayed window.

Pri Master;
Pri Slave;
Sec Master;
Sec Slave

Choose these icons to configure the hard disk drive named in the option. When you click on an icon, the following parameters are listed: Type, LBA/Large Mode, Block Mode, 32Bit Mode, and PIO Mode. All parameters relate to IDE drives except **Type**. Choose the **Type** parameter and select Auto BIOS automatically detects the IDE drive parameters and displays them. Choose on **LBA Mode** and choose *On* to enable support for IDE drives with capacities greater than 528MB. Click on **Blk Mode** and choose *On* to support IDE drives that use Blk Mode. Click on **32Bit Mode** and click on *On* to support IDE drives that permit 32-bit accesses.

Floppy Drive A; B

Choose the Floppy Drive A or B icon to specify the floppy drive type. The settings are 360KB 5¹/₄", 1.2MB 5¹/₄", 720KB 3¹/₂", 1.44MB 3¹/₂", or 2.88MB 3¹/₂".

Advanced CMOS Setup

Choosing the item from the BIOS Setup main menu. All Advanced Setup options are described in this section.

| AMIBIOS SETUP - ADVANCED CMOS SETUP (C)1998 American Megatrends, Inc. All Rights Reserved | |
|--|----------|
| Quick Boot | Enabled |
| 1st Boot Device | IDE-0 |
| 2nd Boot Device | Floppy |
| 3rd Boot Device | CDROM |
| Try Other Boot Devices | Yes |
| S.M.A.R.T. for Hard Disks | Disabled |
| BootUp Num-Lock | On |
| Floppy Drive Swap | Disabled |
| Floppy Drive Seek | Disabled |
| PS/2 Mouse Support | Enabled |
| Password Check | Setup |
| Boot To OS/2 Over 64MB | No |
| Internal Cache | Enabled |
| System BIOS Cacheable | Disabled |
| Video, 32K Shadow | Cached |
| CC00, 16K Shadow | Disabled |
| D000, 16K Shadow | Disabled |
| D400, 16K Shadow | Disabled |
| D800, 16K Shadow | Disabled |
| DC00, 16K Shadow | Disabled |

| | |
|-----------------------------------|-----------------------|
| ESC : Quit | ↑ ↓ → ← : Select Item |
| F1 : Help | PU/PD/+/- : Modify |
| F5 : Old Values (Shift)F2 : Color | |
| F6 : Load BIOS Defaults | |
| F7 : Load Setup Defaults | |

| | |
|--|---|
| Quick Boot | Set this option to <i>Enabled</i> to permit BIOS to boot within 5 seconds. |
| 1st Boot Device; 2nd Boot Device; 3rd Boot Device | Set these options to select the boot sequence from different booting devices. |
| Try Other Boot Devices | Choose <i>Yes</i> or <i>No</i> to search other boot devices to boot up the system when all the options in the previous function failed. |
| S.M.A.R.T for Hard Disks | Choose <i>Enabled</i> or <i>Disabled</i> . This option allows you to utilize the S.M.A.R.T. function of HDDs. |
| Boot Up Num-Lock | Set this option to turn on <i>Num Lock</i> key when the system is powered on. |
| Floppy Drive Swap | This option allows you to swap floppy drives between A: and B:. |
| Floppy Drive Seek | Choose <i>Enabled</i> or <i>Disabled</i> . <i>Disabled</i> provides a faster boot and reduces the possibility of damaging the heads. |
| PS/2 Mouse Support | When this option is set to <i>Enabled</i> , BIOS supports a PS/2-type mouse. |
| Password Check | <p>This option specifies the type of BIOS password protection that is implemented. The settings are:</p> <p>Setup: The password prompt appears only when an end user attempts to run WinBIOS Setup.</p> <p>Always: A password prompt appears every time the computer is powered on or rebooted.</p> <p>The BIOS password does not have to be enabled. The end user sets the password by choosing the Password icon on the WinBIOS Setup screen.</p> |

| | |
|--|---|
| Boot to OS/2 Over 64MB | You need to set this option to Enabled when using the OS/2 operating system with installed DRAM which is greater than 64MB. |
| Internal Cache | This option selects to enable the CPU L1/L2 cache or not. Choices are Disabled and Enabled. |
| System BIOS Cacheable | BIOS always copies the system BIOS from ROM to RAM for faster execution. Set this option to <i>Enabled</i> to permit the contents of the F0000h RAM memory segment to be written to and read from cache memory. |
| Video, 32K Shadow; CC00, 16K Shadow; D000, 16K Shadow; D400, 16K Shadow; D800, 16K Shadow; DC00, 16K Shadow | Disabled: The specified ROM is not copied to RAM. Enabled: The contents of the ROM area are not only copied from ROM to RAM for faster execution, the contents of the RAM area can be written to or read from cache memory. Cached: The contents of the ROM area are copied from ROM to RAM for faster execution. |

Advanced Chipset Setup

Choose the item from the BIOS Setup main menu. All Chipset Setup options are then displayed and are described in the following section:

| AMIBIOS SETUP - ADVANCED CHIPSET SETUP (C)1998 American Megatrends, Inc. All Rights Reserved | |
|---|----------|
| Trend ChipAway Virus | Enabled |
| Set SDRAM Timing By SPD | Enabled |
| SDRAM RAS# to CAS# Delay | 3 SCLKs |
| SDRAM RAS# Precharge | 3 SCLKs |
| SDRAM CAS# Latency | 3 SCLKs |
| SDRAM Leadoff Timing | Auto |
| EDO RASx Wait State | 1 W/S |
| EDO CASx Wait State | 1 W/s |
| DRAM Integrity Mode | Non-ECC |
| DRAM Refresh Rate | 31.2 us |
| Graphics Aperture Size | 64MB |
| 8bit I/O Recovery Time | 1 Sysclk |
| 16bit I/O Recovery Time | 1 Sysclk |
| PCI 2.1 Support | Disabled |
| On Board USB Function | Disabled |
| USB Function for DOS | Disabled |
| Keyboard Power On | Disabled |
| Stroke Keys Selected | Ctrl+F1 |

| | |
|-----------------------------------|-----------------------|
| ESC : Quit | ↑ ↓ → ← : Select Item |
| F1 : Help | PU/PD/+/- : Modify |
| F5 : Old Values (Shift)F2 : Color | |
| F6 : Load BIOS Defaults | |
| F7 : Load Setup Defaults | |

- Trend ChipAway Virus** Choose *Enabled* to activate the Trend ChipAwayVirus function.
- Set SDRAM Timing by SPD** Choose Enabled to set SDRAM timing by PC SDRAM SPD (Serial Presence Detect).
- SDRAM RAS# to CAS# Delay** Set this option to select the proper delay time of SDRAM RAS# to CAS#.
- SDRAM RAS# Precharge** Set this option to select the proper SDRAM RAS# precharge time.
- SDRAM CAS# Latency** This option is designed to select the SDRAM CAS# Latency.
- SDRAM Leadoff Timing** Set this option to select the proper SDRAM Leadoff timing.

| | |
|------------------------------------|--|
| EDO RASx, CASx Wait State | These two options are designed to select the proper Wait State for EDO RASx, and CASx, and these options only support the 66MHz-base system. |
| DRAM Integrity Mode | Choose Non-ECC, EC-Only, or ECC. Non-ECC: Has byte-wise write capability but no provision for protecting data integrity in the DRAM array. EC-Only: Data errors are detected but not corrected. ECC: Allows a detection between single-bit and multiple-bit errors and recovery of single-bit errors. |
| DRAM Refresh Rate | Set this option to select the proper DRAM refresh rate. |
| Graphics Aperture Size | Set this option to select the memory-mapped. Graphics data structures can reside in the Graphics Aperture. Use the default setting. |
| 8, 16 bit I/O Recovery Time | Set these options to specify the length of a delay inserted between consecutive 8-bit or 16-bit I/O operations. |
| PCI 2.1 Support | Set this option to <i>Enabled</i> to support the PCI v2.1 specification. |
| OnBoard USB Function | Set this option to enable the system BIOS USB (Universal serial Bus) functions. |
| USB Function for DOS | Choose Enabled or Disabled. Set this option to enable the passive release on the USB (Universal Serial Bus). |
| Keyboard Power On | Set this option to <i>Enabled</i> to activate the Keyboard Power On function. |
| Stroke Keys Selected | Set this option to specify the stroke keys for keyboard power on. |

Power Management Setup

Choosing the item from BIOS Setup main menu.

| AMIBIOS SETUP - POWER MANAGEMENT SETUP (C)1998 American Megatrends, Inc. All Rights Reserved | | |
|---|----------|--|
| Power Management/APM | Disabled | |
| Green Monitor Power State | Stand By | |
| Video Power Down Mode | Stand By | |
| Hard Disk Power Down Mode | Suspend | |
| Standby Time Out (Minute) | Disabled | |
| Suspend Time Out (Minute) | Disabled | |
| Display Activity | Ignore | |
| Serial port 1 | Monitor | |
| Serial port 2 | Monitor | |
| Paralle port | Ignore | |
| Floppy disk | Monitor | |
| Primary master IDE | Monitor | |
| Primary slave IDE | Ignore | |
| Secondary master IDE | Monitor | |
| Secondary slave IDE | Ignore | |
| LAN Card Power On | Enabled | |
| RTC Alarm Power On | Disabled | |
| RTC Alarm Date | 15 | ESC : Quit ↑ ↓ → ← : Select Item |
| RTC Alarm Hour | 12 | F1 : Help PU/PD/+/- : Modify |
| RTC Alarm Minute | 30 | F5 : Old Values (Shift)F2 : Color |
| RTC Alarm Second | 30 | F6 : Load BIOS Defaults |
| | | F7 : Load Setup Defaults |

Power Management/ APM Set this option to enable power management features and APM (Advanced Power Management).

Green Monitor Power State This option specifies the power state that the green PC-compliant video monitor enters when AMIBIOS places it in a power savings state after the specified period of display inactivity has expired.

Video Power Down Mode This option specifies the power conserving state that the VESA VGA video subsystem enters after the specified period of display inactivity has expired.

Hard Disk Power Down Mode This option specifies the power conserving state that the hard disk drive enters after the specified period of hard drive inactivity has expired.

| | |
|---|---|
| Standby Time out (Minute) | This option specified the length of system inactivity while in Full power on state. When this length of time expires, the computer enters Standby power state. |
| Suspend Time Out (Minute) | This option specified the length of a period of system inactivity while in Standby state. When this length of time expires, the computer enters Suspend power state. |
| Display Activity; Serial Port 1; Serial Port 2; Parallel Port; Floppy disk; Primary master IDE; Primary slave IDE; Secondary master IDE; Secondary slave IDE | When set to Yes, these options enable event monitoring on the specified hardware interrupt request line and the computer is in a power saving state, BIOS watches for activity on the specified IRQ line. The computer enters the full on power state if any activity occurs. |
| LAN Card Power On | Set this option to enable the signal of LAN to resume the system. |
| RTC Alarm Power On | Set this option to enable the RTC Alarm to wake up the system which is Soft Off. |
| RTC Alarm Date; RTC Alarm Hour; RTC Alarm Minute; RTC Alarm Second | Set these options to specify the RTC Alarm time on Date/Hour/Minute/Second. |

PCI/Plug and Play Setup

Choose the item from the BIOS Setup main menu.

| AMIBIOS SETUP - PCI / PLUG AND PLAY SETUP (C)1998 American Megatrends, Inc. All Rights Reserved | | | |
|--|----------|-------------------------|----------|
| Plug and Play Aware O/S | Yes | IRQ14 | PCI/PnP |
| Primary Graphics Adapter | AGP | IRQ15 | PCI/PnP |
| PCI VGA Palette Snoop | Disabled | Reserved Memory Size | Disabled |
| Assign IRQ for VGA | No | Reserved Memory Address | C8000 |
| OffBoard PCI IDE Card | Auto | | |
| Pri. OffBoard PCI IDE IRQ | Disabled | | |
| Sec. OffBoard PCI IDE IRQ | Disabled | | |
| DMA Channel 0 | PnP | | |
| DMA Channel 1 | PnP | | |
| DMA Channel 3 | PnP | | |
| DMA Channel 5 | PnP | | |
| DMA Channel 6 | PnP | | |
| DMA Channel 7 | PnP | | |
| IRQ3 | PCI/PnP | | |
| IRQ4 | PCI/PnP | | |
| IRQ5 | PCI/PnP | | |
| IRQ7 | PCI/PnP | | |
| IRQ9 | PCI/PnP | | |
| IRQ10 | PCI/PnP | | |
| IRQ11 | PCI/PnP | | |

| | |
|-----------------------------------|-----------------------|
| ESC : Quit | ↑ ↓ → ← : Select Item |
| F1 : Help | PU/PD/+/- : Modify |
| F5 : Old Values (Shift)F2 : Color | |
| F6 : Load BIOS Defaults | |
| F7 : Load Setup Defaults | |

Plug and Play Aware OS Set this option to *Yes* if the operation system in this computer is aware of and follows the Plug and Play specification. Currently, only Windows 95 is PnP-aware.

Primary Graphics Adapter Set this option to select AGP or PCI VGA for primary graphics adapter.

PCI VGA Palette Snoop When this option is set to Enabled, multiple VGA devices operating on different buses can handle data from the CPU on each set of palette registers on every video device. Bit 5 of the command register in the PCI device configuration space is the VGA Palette Snoop bit.

Assign IRQ for VGA This option is used to allocate IRQ to PCI VGA. Recommendation is set to *No*.

| | |
|---|--|
| OffBoard PCI IDE Card | This option specifies if an offboard PCI IDE controller adapter card is installed in the computer. You must specify the PCI expansion slot on the motherboard where the offboard PCI IDE controller is installed. If an offboard PCI IDE controller is used, the onboard IDE controller is automatically disabled. If an offboard PCI IDE controller adapter card is installed in the computer, you must also set the Offboard PCI IDE Primary IRQ and Offboard PCI IDE Secondary IRQ options. |
| Pri. OffBoard PCI IDE IRQ; Sec. OffBoard PCI IDE IRQ | These options specify the PCI interrupt used by the Primary (or secondary) IDE channel on the offboard PCI IDE controller. |
| DMA Channel 0, 1, 3, 5, 6, 7 | These options specify the bus that the specified DMA channel is used on. |
| IRQ3, 4, 5, 7, 9, 10, 11, 14, 15 | These options specify the bus that the specified IRQ line is used on. These options allow you to reserve IRQs for legacy ISA adapter cards. |
| Reserved Memory Size | This option is designed to be used for reserving memory for the IO card. |
| Reserved Memory Address | This option is designed to be used for reserving memory address for the IO card. |

Peripheral Setup

Choose the item from the BIOS Setup main menu.

| AMIBIOS SETUP - PERIPHERAL SETUP | |
|---|-----------|
| (C)1998 American Megatrends, Inc. All Rights Reserved | |
| OnBoard FDC | Enabled |
| OnBoard Serial Port1 | 3F8h/COM1 |
| OnBoard Serial Port2 | 2F8h/COM2 |
| Serial Port2 Mode | Normal |
| IR Duplex Mode | Full |
| OnBoard Parallel Port | 378h |
| Parallel Port Mode | Normal |
| Parallel Port IRQ | 7 |
| Parallel Port DMA | N/A |
| OnBoard IDE | Both |

| | |
|--------------------------|-----------------------|
| ESC : Quit | ↑ ↓ → ← : Select Item |
| F1 : Help | PU/PD/+/- : Modify |
| F5 : Old Values (Shift) | F2 : Color |
| F6 : Load BIOS Defaults | |
| F7 : Load Setup Defaults | |

OnBoard FDC This option enables the FDC (Floppy Drive Controller) on the motherboard or auto detects the FDC.

OnBoard Serial Port1 This option specifies the base I/O port address of serial port 1.

OnBoard Serial Port2 This option specifies the base I/O port address of serial port 2.

Serial Port2 Mode This option specifies the serial port2 mode.
 Normal: The normal serial port mode is being used.
 IrDA/ASKIR: The serial port2 will be redirected to support IR function when this option is set to IrDA or ASKIR.

IR Duplex Mode This option is to specify the Duplex mode of Serial Port 2.

OnBoard Parallel Port This option specifies the base I/O port address of the parallel port on the motherboard.

Parallel Port Mode Depends on the type of your external device which connects to this port to choose Normal, EPP, or ECP mode.

Parallel Port IRQ This option specifies IRQ to parallel port.

Parallel Port DMA This option is only available if the setting of the Parallel Port Mode option is EPP/ECP.

OnBoard IDE This option specifies the channel used by the IDE controller on the motherboard.

H/W Monitor & CPU PnP Setup

Choose this item from the BIOS Setup main menu.

| AMIBIOS SETUP - H/W Monitor & CPU PnP SETUP | |
|---|------------|
| (C)1998 American Megatrends, Inc. All Rights Reserved | |
| CPU Speed (MHz) | 300(100x3) |
| CPU Clock OverDrive | Disabled |
| CPU1 Temperature | 31°C/87°F |
| CPU2 Temperature | 30°C/86°F |
| Fan1 Speed | 2105 RPM |
| Fan2 Speed | 0 RPM |
| Vcc | 5.200 V |
| Vcc3 | 3.268 V |
| Vcore | 2.033 V |
| +12V | 12.482 V |
| ESC : Quit ↑ ↓ → ← : Select Item F1 : Help PU/PD/+/- : Modify F5 : Old Values (Shift) F2 : Color F6 : Load BIOS Defaults F7 : Load Setup Defaults | |

CPU Speed (MHz) Select a correct CPU speed to match your CPU.

CPU Clock OverDrive Set this option to Enabled so that user can overdrive CPU.

CPU1, CPU2 Temperature; These options are displayed only show the status of system hardware.

Fan1, Fan 2 Speed;
Vcc; Vcc3; Vcore;
+12V

Change Supervisor Password

This item lets you configure the system password which is required every time when the system boots up or an attempt is made to enter the Setup program. The password cannot be longer than six characters.

Note: Keep a safe record of the new password. If you forget or lose the password, the only way to access the system is to clear CMOS memory by holding down the <End> key then powering on to reboot the system.

Auto-Detect Hard Disks

If your system has an IDE hard drive, you can use this utility to detect its parameters and automatically enter them into the Standard CMOS Setup. This utility will autodetect up to four IDE devices.

Save Settings and Exit

Select this item to save the values entered during the current session and then exit the BIOS setup program.

Exit Without Saving

Select this item to exit the BIOS setup program without saving the values which has been entered during the current session.

Chapter 4

SoftWare Driver

The CD came with the package is free of charge and includes all our products' drivers and the path of this mainboard's drivers and utilities are listed below:

- ❑ IDE Driver for Windows 95
(CD-ROM): \IDE\M750\Win95\Setup.exe
- ❑ VGA Driver Path
(CD-ROM): \VGA\I740AGP\
- ❑ USB Driver for Windows 95
(CD-ROM): \USB\Eusbsupp\Usbsupp.exe;
(CD-ROM): \USB\Cusbsupp\Cusbsupp.exe for
Chinese Windows95
- ❑ Sound Driver Path
(CD-ROM): \SOUND\PCI SoundPro\
- ❑ BIOS Update Utility
(CD-ROM): \UTILITY\AMifl806a.exe
- ❑ Bundled PC-cillin Path
(CD-ROM): \PC-cillin\
- ❑ Bundled ADCM Path
(CD-ROM): \AMIADCM\