

The information presented in this publication has been carefully checked for reliability; however, no responsibility is assumed for inaccuracies. Specifications are subject to change without notice.

Trademarks

IBM, PC/AT, and PC/XT are trademarks of International Business Machines Corporation.

Intel and Pentium® II are trademarks of Intel Corporation.

AMI is a trademark of American Megatrends Inc.

MS-DOS and WINDOWS 95/98/NT are registered trademarks of Microsoft Corporation.

Sound Blaster and SB-Link are trademarks of Creative Technology Ltd.

PC-cillin and ChipAwayVirus are trademarks of Trend Micro, Inc.

Contents

Chapter 1: Introduction	1
Key Features	2
Unpacking the Mainboard & Static Electricity Precautions.....	5
Chapter 2: Hardware Configuration	6
Mainboard Component Locations	7
CPU Installation	8
Installation Procedures.....	9
CPU Speed Setting.....	11
Memory Installation.....	12
J13 – DIMM Voltage Selectors	12
Jumper Settings	13
RTC – CMOS RAM Clear Selector	13
J16 – Keyboard Power On Selector	14
ATX Functions & Connectors.....	14
Software Power-Off	14
Modem Ring Power-On	15
Alarm Wake Up	15
Keyboard Power-On	15
CN1 – ATX Power Connector	15
J11 (21, 22) (PWRBT) – Power Button and Suspend Switch Connector	16
Connectors.....	16
External Connectors Location.....	17
FDC1 – Floppy Disk Drive Connector	17
IDE1/IDE2 – Primary/Secondary IDE Connectors	17
J12, J14 – CPU, SYS Fan Power Connectors	18
IR – Infrared Connector	18
Case Connectors: J11	19
J11 (2, 4, 6) (Power LED) – Power LED Connector	19
J11 (8, 10) (KEYLOCK) – KeyLock Switch Connector	19
J11 (1, 3, 5, 7) (SPK) – Speaker Connector.....	20
J11 (13, 14) (SP-LED) – Suspend LED Connector.....	20
J11 (15, 16) (HD-LED) – HDD LED Connector	20
J11 (17, 18) (RST) – Reset Switch Connector	20
J15 – Suspend Blinking LED Connector.....	20
Onboard Sound Pro	21
Sound and Game (on the External Connectors).....	21
J19/J20 – Analog Audio from CD-ROM.....	22
J17 – Digital Audio OUT	23

J18 – Digital Audio IN	23
Sound Pro Drivers Installation and Application	24
Chapter 3: BIOS Setup	25
Entering BIOS Setup	26
Default	26
Load Optimal Settings	26
Load Best Performance Settings	26
Setup Items	27
Standard CMOS Setup	27
Advanced CMOS Setup	29
Advanced Chipset Setup	31
Power Management Setup	34
PCI/Plug and Play Setup	37
Peripheral Setup	39
CPU Plug and Play Setup	41
Change Supervisor Password	42
Auto-Detect Hard Disks	42
Save Settings and Exit	42
Exit Without Saving	42
Chapter 4: SoftWare Driver	43

Chapter 1

Introduction

This mainboard is an **Intel 440BX 100MHz** highly integrated high-performance mainboard based on the advanced Pentium® II microprocessor and provides CPU Plug and Play feature for faster and easier CPU installation. The mainboard features highly flexible configurations and is fully IBM PC/AT compatible.

The mainboard uses a high-end AGPset chipset that supports the PCI/ISA and Green standards, provides the Host/AGP bridge, and integrates all system control functions such as ACPI(Advanced Configuration and Power Interface). The **ACPI** provides more energy saving features for the OSPM(OS Direct Power Management) function.

The mainboard has a built in high performance 64-bit 3D AGP Graphics Accelerator with 8MB frame buffer and an onboard 3D Sound Pro to meet PC98' specifications for 3D Multimedia systems, and built-in **Hardware Monitor** circuit to monitor CPU/Chasis temperatures/fan speeds/voltages with AMI **Desktop Client Manager** and options to support Intel LANDesk Client Manager(LDCM). And the mainboard BIOS provides Trend's ChipAwayVirus to ensure the entire boot process virus free.

Key Features

The advanced features of the mainboard include:

- ❑ Intel 440BX AGP chipset:
 - supports Pentium® II 233~500MHz and Celeron 266~333MHz CPUs
 - supports both 66.6MHz and 100MHz FSB (Front Side Bus)
 - provides CPU Plug and Play feature for faster and easier CPU installation

- ❑ Memory:
 - provides 3 DIMMs for SDRAM/EDO (for 66MHz FSB only) memory modules
 - supports a maximum size of 768MB system memory
 - supports ECC Error Correct function

- ❑ Expansion slots:
 - provides 3 PCI, and 1 ISA slots;

- ❑ Onboard 2 IDE ports:
 - supports 4 IDE devices maximum
 - supports PIO, PCI Bus Master and Ultra DMA/33 operation modes

- ❑ ATX Power Supply:
 - provides ATX power connector and features of ATX power
 - provides Power Button/Suspend Switch and **Keyboard Power On** functions
 - Alarm Wake Up and Modem Wake Up functions

- ❑ Onboard DC-DC Step Down Regulator:
 - complies with Intel VRM V8.2 specification

- ❑ Onboard 64-bit 3D AGP Graphics Accelerator:
 - supports AGP Ver1.0 specification compliant and 66/133MHz
 - provides 8MB frame buffer
 - high resolution graphic modes up to 1600x1200

- ❑ Onboard 3D SoundPro Features:
 - meets PC98' specifications
 - supports both Sound Blaster 16/Pro and Windows Sound System
 - supports **HRTF 3D** Positional Audio technology
 - provides drivers for Windows Direct Sound 3D
 - provides drivers for 3D games that use Aureal software interface
 - built-in Digital Audio Interface (SPDIF) In/Out
 - built-in software Wave-Table Synthesizer
 - built Duplex 16-bit CODEC with filters
 - Stereo Mixer supports analog mixing from CD-Audio, Line-In, and digital mixing from voice, FM/Wave-Table and digital CD-Audio

- ❑ Onboard Multi-I/O and Peripheral interface, including:
 - 1 floppy port with 1 MB/s transferring rate
 - 2 serial ports with 16550 compatible with Fast UART
 - 1 parallel port with EPP and ECP capabilities
 - 2 USB ports and PS/2 keyboard/mouse ports
 - 1 IR interface

- ❑ Built-in Hardware Monitor circuit:
 - detects CPU/Chasis temperature and fan speed
 - displays actual current voltages
 - supports Intel LANDesk Client Manager (LDCM)

- ❑ BIOS:
 - Onboard **2M Flash ROM** supports complete ACPI and Legacy PMU and is fully compatible with PC97 and PC98
 - provides Plug & Play function which detects the peripheral devices and expansion cards automatically
 - supports Trend's **ChipAwayVirus** option to ensure the entire boot process is virus free, no installation and configuration worries

- ❑ Bundled:
 - AMI **Desktop Client Manager** detects abnormal condition and thermal management through the network link or self care
 - **PC-cillin98** (OEM) provides automatic virus protection for Windows 95/98 and the Internet

- ❑ Dimension:
 - ATX Form Factor, 24.4cm (L) x 22cm (W)

Unpacking the Mainboard & Static Electricity Precautions

This Mainboard package contains the following items:

1. This Mainboard and the Device Driver
2. The Slot1 holder and AT cables
3. This User's Guide
4. SPDIF/IN cable
5. VGA cable/bracket

The mainboard is easily damaged by static electricity. Follow the precautions below while unpacking or installing the mainboard.

1. Do not remove the mainboard from its original package until you are ready to install it.
2. Frequently ground yourself to discharge any static electric charge that may build up in your body while working on installation and/or configuration. For example, you may ground yourself by grasping an unpainted portion of the system's metal chassis.
3. Remove the mainboard from its anti-static packaging and place it on a grounded surface, component side up.
4. Handle the mainboard by its edges or by the mounting bracket to avoid touching its components.
5. Check the mainboard for damage. If any integrated circuit appears loose, press carefully to seat it firmly in its socket.
6. Do not apply power if the mainboard appears damaged. If there is damage to the board contact your dealer immediately.

Chapter 2

Hardware Configuration

Before you install the mainboard into the system chassis, you may find it convenient to first configure the mainboard's hardware. This chapter describes how to set jumpers and install memory modules, and where to attach components, however, the CMOS jumper is set on the "Clear" position when this mainboard is shipped and you need to set it to the "Normal" position in order for the mainboard perform properly.

Warning: *Set RTC to "Normal" position before setting other jumpers or memory modules. This mainboard will not function properly if you fail to do so.*

Mainboard Component Locations

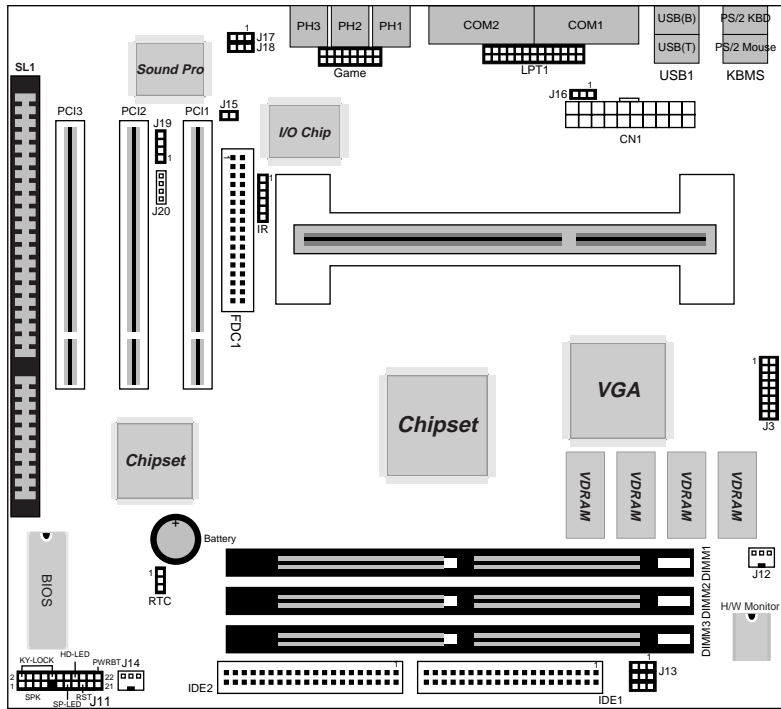
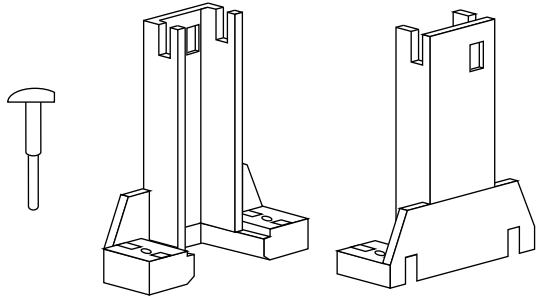

Figure 2-1. Mainboard Component Locations

CPU Installation

This mainboard supports Intel Pentium® II CPU using a Single Edge Contact (SEC) slot and a retention clip, as is shown in the following drawing which has been pre-installed before shipping to make the CPU installation easier for users. However, there are still a few more steps needed to complete the CPU installation, refer to following procedures.



Installation Procedures

Follow the following steps in order to install your Intel Pentium® II properly.

Step 1:

Make sure that the mainboard is set the same direction as the following drawing before doing any installation.

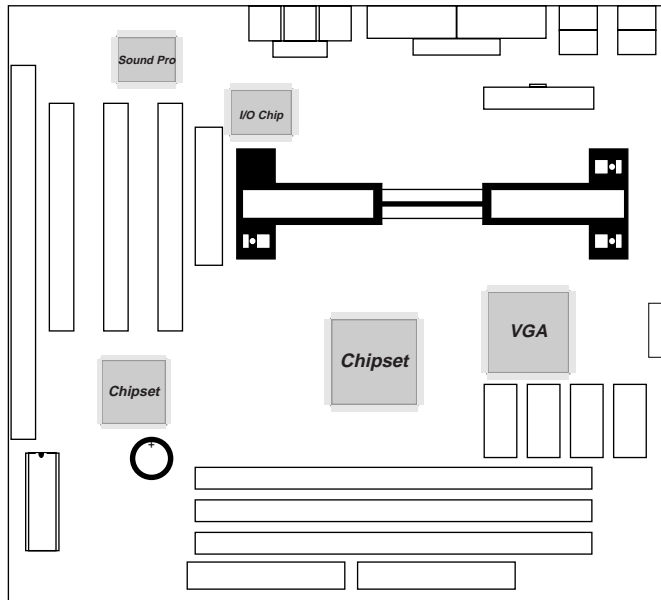

Step 2:

There is one set of the Slot1 Holder retention that was installed on your motherboard, and the two chutes of Holder retention are screwed in. Lift up both of the Holder chutes as shown in the following drawing.

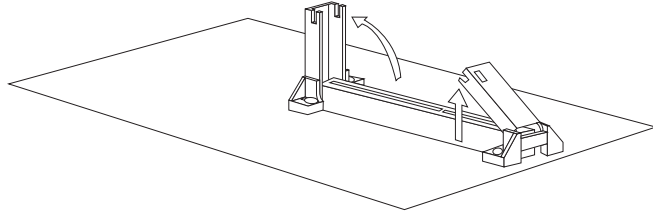
**Step 3:**

Flatten the two latches on the side of CPU. Insert the CPU into the Holder retention. Lock the two latches to secure the CPU.

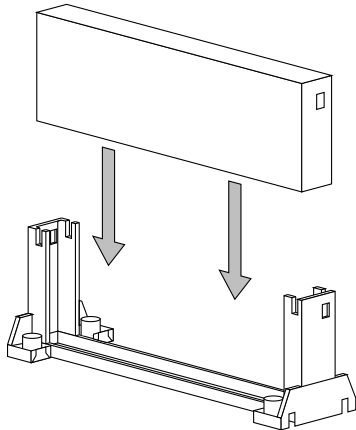

If CPU is Celeron, then, continue the following step.

Step 4:

After installing Celeron CPU into the Holder retention, then push the retention locker (only for Celeron CPU) downward to secure the Celeron CPU as indicated in the following 2 drawings.

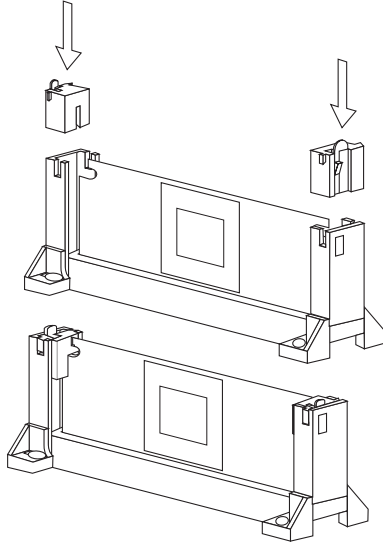
**CPU Speed Setting**

This mainboard provides CPU Plug and Play technology, so that there is no need to do the CPU jumper setting. Enter the BIOS Setup and select “CPU Plug and Play Setup”. Choose the correct CPU speed to match your CPU installed.

However, if you need to change a CPU, follow the below steps:

1. Power off system and unplug the power core.
2. Install a new CPU to Slot1.
3. Clear CMOS RAM (see Jumper Settings) then power on the system.
4. After power on the system, then enter the BIOS Setup section to set the new CPU speed.

Note: If the CPU speed is set incorrectly and fails to boot up the system, then repeat steps 1, 3, 4 again.

Memory Installation

The mainboard lets you add up to 768MB of system memory through 3 DIMM sockets on the board, that is divided into 3 banks: Bank 0, Bank 1, and Bank 2, which supports the following memory configurations.

Bank	Memory Module
Bank 0	
DIMM1	4MB, 8MB, 16MB, 32MB, 64MB, 128MB, 256MB
Bank 1	
DIMM2	4MB, 8MB, 16MB, 32MB, 64MB, 128MB, 256MB
Bank 2	
DIMM3	4MB, 8MB, 16MB, 32MB, 64MB, 128MB, 256MB
Total System Memory = Bank 0 + Bank 1 + Bank 2	

- Notes:
1. The speed of SDRAM DIMM modules have to be faster than 12ns (“-12” parts), while 100MHz clock speed used, the speed of SDRAM DIMM should meet the PC100 SDRAM specification (8ns or “-8” SDRAM at least).
 2. The EDO/FPM DRAM are not recommended for the performance purpose of the system.

J13 – DIMM Voltage Selectors

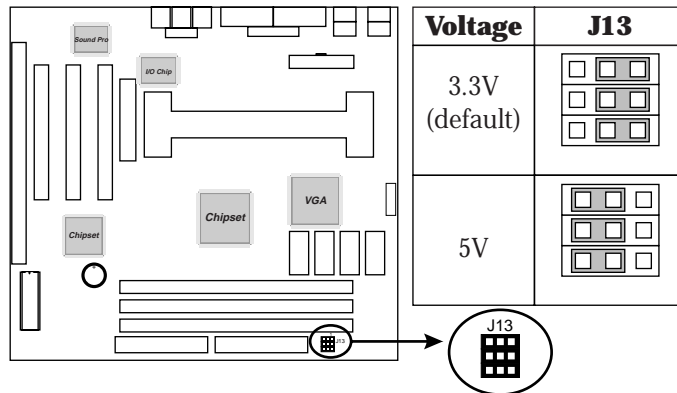

Jumper Settings

RTC – CMOS RAM Clear Selector

The battery on this mainboard is designed to retain the system configuration in CMOS RAM. In order to save the life of the battery, this jumper is set to “Clear CMOS” position when this board is shipped, therefore, you need to set this jumper to “Normal” position before setting other jumpers or memory modules.

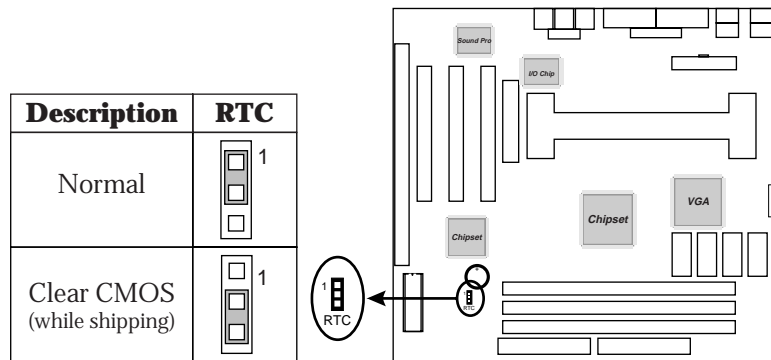

- Note:*
- 1. This jumper needs to be set on Normal Mode before using.*
 - 2. Turn off the system and unplug the power core when you need to clear the CMOS.*

J16 – Keyboard Power On Selector

This jumper is designed for the user to turn on the system by using the keyboard, and, the user must enter BIOS Setup to set the “Keyboard Power ON” and the “Stroke Keys Selected” options in the Advanced Chipset Setup.

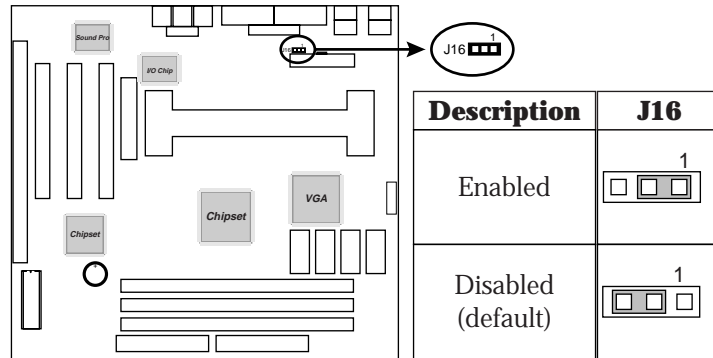

Note: Make sure that the system power can provide 800mA on +5VSB(+5V Standby) signal before using Keyboard Power On function.

ATX Functions & Connectors

This mainboard supports ATX power and ACPI specification. The ATX functions and connectors are described below.

Software Power-Off

Follow the steps below to use the “Software Power-Off Control” function in Windows 95/98 with ATX power supply.

1. Click the **START** button on the Windows 95/98 task bar.
2. Select **Shut Down The Computer** to turn off the computer. The message “**It is now safe to turn off your computer.**” will not be shown when using this function.

Modem Ring Power-On

While in Soft-off/Suspend state, if an external modem ring-up signal occurs, the system wakes up and can be remotely accessed. Make sure that the Serial Port 2 option in the Power Management Setup of the BIOS Setup section is set to "Monitor" and the Ring Resume From OFF option is set to "Enabled".

Alarm Wake Up

If you want to autoboot the system at a certain time, set the function of RTC Alarm time properly and the function of RTC Resume From Off option in the BIOS Setup section will be set to "Enabled."

Keyboard Power-On

Press the hot key to power on the system when the K/B Resume From option is set to "Enabled" in the BIOS Setup section, and you can press any keys to power on your system.

CN1 – ATX Power Connector

The ATX power supply is a single 20-pin connector. Connect the ATX power supply to this connector which provides all power for the mainboard.

Pin	Description	Pin	Description	Pin	Description	Pin	Description
1	3.3V	6	+5V	11	3.3V	16	Ground
2	3.3V	7	Ground	12	-12V	17	Ground
3	Ground	8	Power OK	13	Ground	18	-5V
4	+5V	9	5VSB	14	PS-ON	19	+5V
5	Ground	10	+12V	15	Ground	20	+5V

J11 (21, 22) (PWRBT) – Power Button and Suspend Switch Connector

Attach the ATX Power Button cable to this connector.

In the AT power system, this connector will act as a suspend switch; and in the ATX power system, this connector will be not only an ATX power button but a Suspend switch as well. Details are described below:

Turn the system back on by pushing the power button, and, if the system is already on, pushing the power button allows the system to be switched to the Suspend mode. However, if push and hold the power button for more than 4 seconds, then the system will be turned off completely.

And, if the system is already in the Suspend mode, pushing the power button rapidly will turn on the system.

Connectors

Attach system components and case devices to the mainboard via the mainboard connectors. A description of each connector pins follows. See Figure 2-1 for the location of the connectors on the mainboard.

Note: Make sure that the power is turned off before making any connection to the board.

External Connectors Location

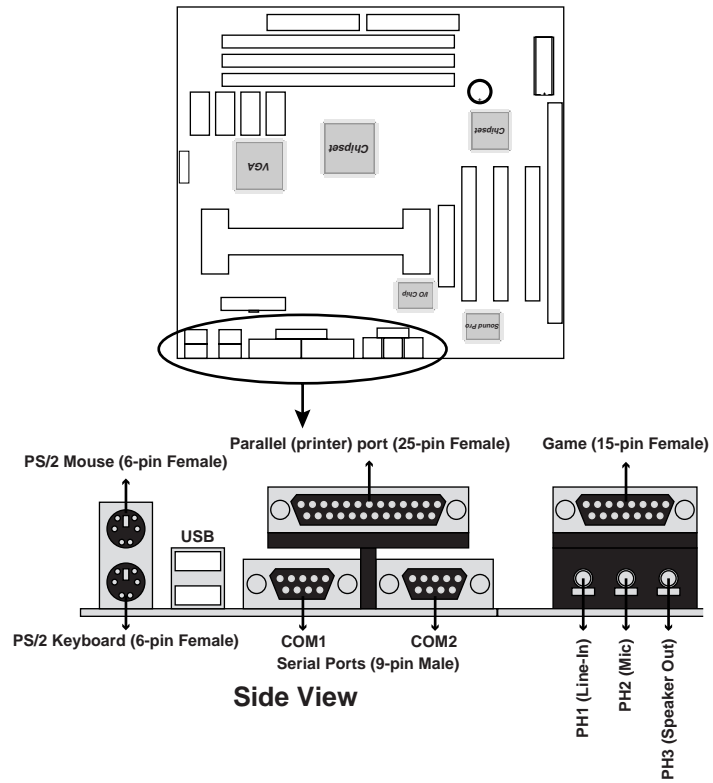

FDC1 – Floppy Disk Drive Connector

IDE1/IDE2 – Primary/Secondary IDE Connectors

J3 – VGA Connector

Connect VGA cable/bracket to this connector.

J12, J14 – CPU, SYS Fan Power Connectors

Connect CPU/System fan cables to J12 and J14. See the following drawing for the locations on the mainboard.

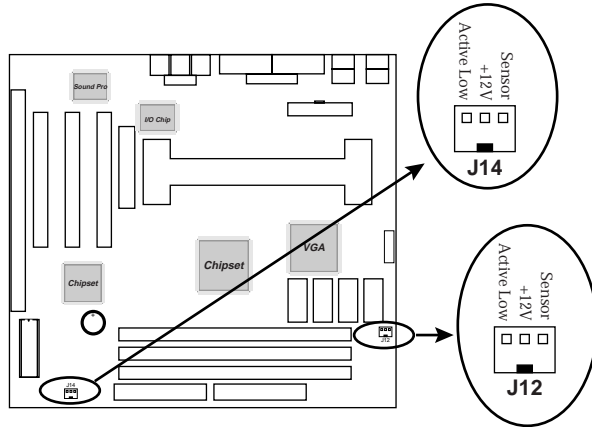

IR – Infrared Connector

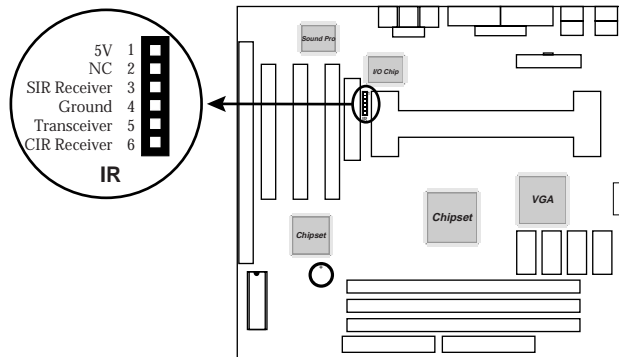

Case Connectors: J11

This connector contains: Speaker, Power LED, Keylock, Suspend LED, HDD LED, Reset Switch, and Power Button. Refer to the following drawing for the location on the mainboard.

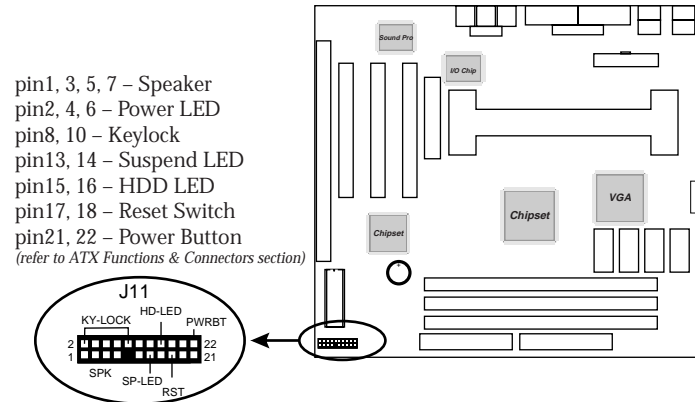

J11 (2, 4, 6) (Power LED) – Power LED Connector

Keylock connector enables and disables the keyboard key-in function on the case.

Pin	Description
2	LED Output
4	N.C.
6	Ground

J11 (8, 10) (KEYLOCK) – KeyLock Switch Connector

Setting	Description
Open	Nomral Mode
Close	Lock K/B

J11 (1, 3, 5, 7) (SPK) – Speaker Connector

Pin	Description
1	+5V
3	N.C.
5	Ground
7	Data Out

J11 (13, 14) (SP-LED) – Suspend LED Connector

Pin	Description
13 (+)	Active High
14 (-)	Ground

J11 (15, 16) (HD-LED) – HDD LED Connector

Pin	Description
15 (+)	+5V
16 (-)	Active Low

J11 (17, 18) (RST) – Reset Switch Connector

Setting	Description
Open	Normal Mode
Close	Reset System

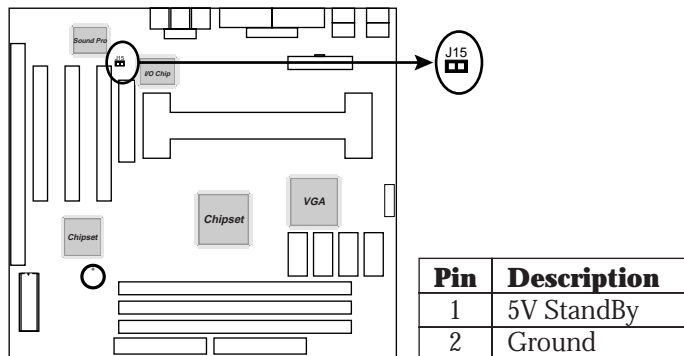
J15 – Suspend Blinking LED Connector

Onboard Sound Pro

Sound and Game (on the Externals Connectors)

This connector provides Line-IN, MIC (Microphone), Line-Out (Speaker) signals for audio I/O, and Game Port (which is also used as the Joystick/MIDI port) signals.

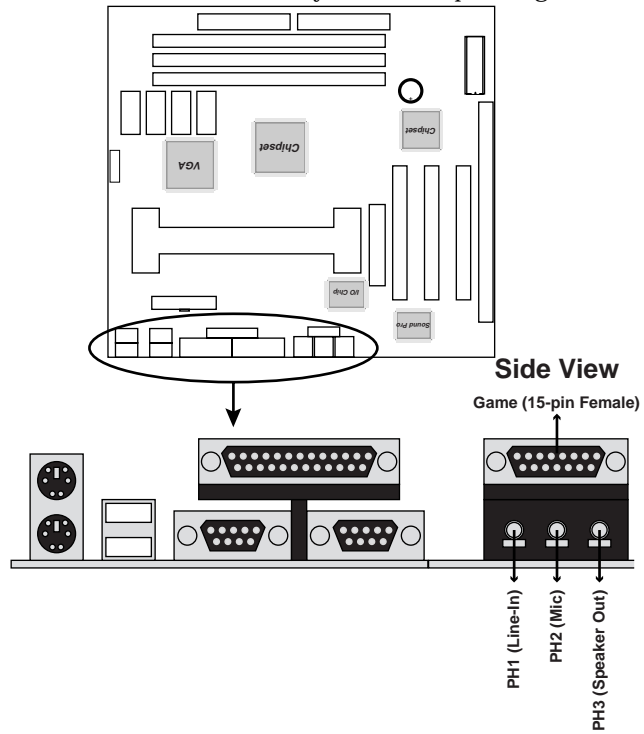

J19/J20 – Analog Audio from CD-ROM

Connect from “AUDIO” output of the CD-ROM driver to these connectors. For Panasonic or compatible type of CD-ROM, connect to J20 (pin signals assignment is G-L-G-R), and for Sony or compatible type of CD-ROM, connect to J19 (pin signals assignment is L-G-G-R).

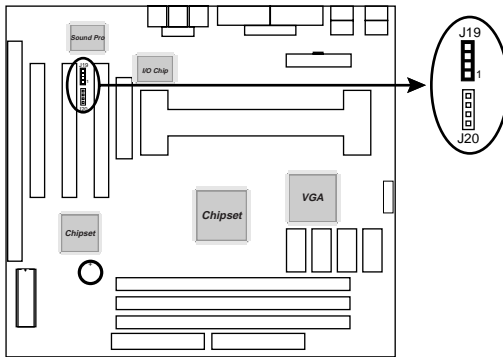

J17 – Digital Audio OUT

Connect to the external Audio Amplifier or Mini-Disk by using optional SPDIF/OUT bracket/cable set, selectable output signal level depends on the device needed. Connect to pin1 and pin2 for 5V signal level or pin3 and pin2 for 0.5V signal level.

Pin	Signals
1	5V Signal
2	Ground
3	0.5V Signal

J18 – Digital Audio IN

Connect to “DIGITAL AUDIO” port of the CD-ROM drive by using the SPDIF/IN cable, which gives you the non-distortion digital audio from CD-ROM. Connect to pin1 and pin2 for 5V signal level or pin3 and pin2 for 0.5V signal level.

Pin	Signals
1	5V Signal
2	Ground
3	0.5V Signal

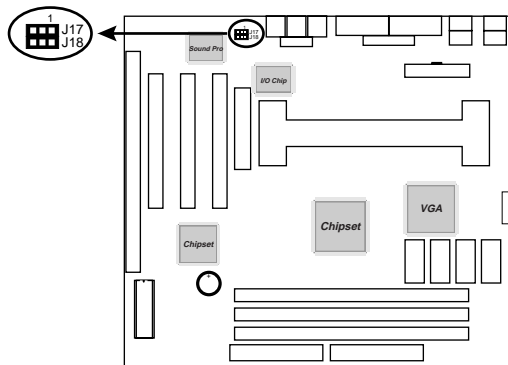

Sound Pro Drivers Installation and Application

This section describes the procedures and proper applications which are recommended for this mainboard.

1. Before installing the Sound Pro drivers, make sure that the operating system has been installed, otherwise the Sound Pro may be detected as “Other Device” by the device manager of the OS.
2. After finishing the driver installation, select the MULTIMEDIA icon in the CONTROL PANEL. Select WSS (Windows Sound System) as the equipment option when playback, and select the SB16 (Sound Blaster 16) as the equipment option while recording, then click “OK” to confirm, to ensure that the chip works with full duplex applications.
3. Select MULTIMEDIA icon in the Control Panel to use Software Wave-Table drivers as MIDI output device. Select MIDI page, click on “SoftMIDI Driver”, and click “OK” to confirm it.
4. A Windows application named is provided within Sound Pro drivers, which gives you the control over all audio functions through a user interface which is as simple as using a home stereo system. It is recommended that user uses the System Mixer in the Audio Rack to control the volume, select recording device, and be able to record again.
5. If the MIDI port is used as a control interface, the “MPU-401 MIDI” needs to be enabled through the MIDI device setting of Sound Pro Audio Rack.
6. Refer to the attached CD for more information on Sound Pro.

Chapter 3

BIOS Setup

This chapter explains how to configure the mainboard's BIOS setup program. The setup program provided with the mainboard is the BIOS from AMI.

After you have configured the mainboard and have assembled the components, turn on the computer and run the software setup to ensure that the system information is correct.

The software setup of the system board is achieved through Basic Input-Output System (BIOS) programming. You use the BIOS setup program to tell the operating system what type of devices are connected to your system board.

The system setup is also called CMOS setup. Normally, you need to run system setup if either the hardware is not identical with information contained in the CMOS RAM, or if the CMOS RAM has lost power.

Note: Hold down the <End> key then power on to reboot the system when installing newer BIOS into this mainboard .

Entering BIOS Setup

To enter the BIOS Setup program:

1. Turn on or reboot the system. A screen appears with a series of diagnostic checks.
2. When “Hit if you want to run SETUP” appears, press the key to enter the BIOS setup program. The following screen appears:

AMIBIOS SIMPLE SETUP UTILITY - VERSION 1.1X (C)1998 American megatrends, Inc. All Rights Reserved	
Standard CMOS Setup	Peripheral Setup
Advanced CMOS Setup	CPU Plug and Play Setup
Advanced Chipset Setup	Change Supervisor Password
Power Management Setup	Auto-Detect Hard Disks
PCI/Plug and Play Setup	Save Settings and Exit
Load Optimal Settings	Exit Without Saving
Load Best Performance Settings	
Esc: Quit ↑ ↓ → ←: Select Item (Shift) F2: Change Color F5: Old Values F6: Optimal values F7: Best performance values F10 : Save&Exit	
Standard CMOS setup for changing time, date, hard disk type, etc.	

3. Use your keyboard to choose options. Modify system parameters to reflect system options. Press Alt-H for Help.

Default

Every option in the BIOS Setup contains two default values: Best default and the Optimal default value.

Load Optimal Settings

The Optimal default values provide optimum system settings for all devices and system features.

Load Best Performance Settings

The Best default values provide best performance settings for all devices and system features, however depending on the devices used, these settings are not recommend for long hours of work load.

Setup Items

Standard CMOS Setup

Choosing the item from the BIOS Setup main menu. All Standard Setup options are described in this section.

AMIBIOS SETUP - STANDARD CMOS SETUP											
(C)1998 American Megatrends, Inc. All Rights Reserved											
Date (mm:dd:yy) : Sat Oct 17, 1998											
Time (hh:mm:ss) : 00:32:28											
	TYPE	SIZE	Cyln	Head	WPcom	Sec	LBA Mode	Blk Mode	PIO Mode	32Bit Mode	
Pri Master	: Auto									On	
Pri Slave	: Auto									On	
Sec Master	: Auto									On	
Sec Slave	: Auto									On	
Floppy Drive A : 1.44MB 31/2"											
Floppy Drive B : Not Installed											
Base Memory : 640 Kb											
Other Memory : 384 Kb											
Extended Memory : 0 Mb											
Total Memory : 1 Mb											
Month: Jan - Dec						ESC : Exit					
Day: 01 - 31						↑↓ : Select Item					
Year: 1901 - 2099						PU/PD/+/- : Modify					
						(Shift)F2 : Color					

Date/Time Select the Date/Time option to change the date or time. The current date and time are displayed. Enter new values through the displayed window.

Pri Master;
Pri Slave;
Sec Master;
Sec Slave Choose these icons to configure the hard disk drive named in the option. When you click on an icon, the following parameters are listed: Type, LBA/Large Mode, Block Mode, 32Bit Mode, and PIO Mode. All parameters relate to IDE drives except **Type**. Choose the **Type** parameter and select Auto BIOS automatically detects the IDE drive parameters and displays them. Choose on **LBA Mode** and choose *On* to enable support for IDE drives with capacities greater than 528MB. Click on **Blk Mode** and choose *On* to support IDE drives that use Blk Mode. Click on **32Bit Mode** and click on *On* to support IDE drives that permit 32-bit accesses.

**Floppy Drive
A; B**

Choose the Floppy Drive A or B icon to specify the floppy drive type. The settings are 360KB 5¹/₄", 1.2MB 5¹/₄", 720KB 3¹/₂", 1.44MB 3¹/₂", or 2.88MB 3¹/₂".

Advanced CMOS Setup

Choosing the item from the BIOS Setup main menu. All Advanced Setup options are described in this section.

AMIBIOS SETUP - ADVANCED CMOS SETUP (C)1998 American Megatrends, Inc. All Rights Reserved			
Quick Boot	Disabled	DC00,16K Shadow	Disabled
1st Boot Device	Floppy		
2nd Boot Device	IDE-0		
3rd Boot Device	CDROM		
Try Other Boot Devices	Yes		
S.M.A.R.T. for Hard Disks	Disabled		
BootUp Num-Lock	On		
Floppy Drive Swap	Disabled		
Floppy Drive Seek	Disabled		
PS/2 Mouse Support	Enabled		
Password Check	Setup		
Boot To OS/2 > 64MB	No		
System BIOS Cacheable	Disabled		
C000,16K Shadow	Cached		
C400,16K Shadow	Cached		
C800,16K Shadow	Disabled		
CC00,16K Shadow	Disabled		
D000,16K Shadow	Disabled		
D400,16K Shadow	Disabled		
D800,16K Shadow	Disabled		
		ESC : Quit ↑ ↓ → ← : Select Item F1 : Help PU/PD/+/- : Modify F5 : Old Values (Shift)F2 : Color F6 : Load BIOS Defaults F7 : Load Setup Defaults	

Quick Boot Set this option to *Enabled* to permit BIOS to boot within 5 seconds.

**1st Boot Device;
2nd Boot Device;
3rd Boot Device** Set these options to select the boot sequence from different booting devices.

Try Other Boot Devices Choose *Yes* or *No* to search other boot devices to boot up the system when all the options in the previous function failed.

S.M.A.R.T for Hard Disks Choose Enabled or Disabled. This option allows you to utilize the S.M.A.R.T. function of HDDs.

Boot Up Num-Lock Set this option to turn on *Num Lock* key when the system is powered on.

Floppy Drive Swap This option allows you to swap floppy drives between A: and B:.

Floppy Drive Seek	Choose Enabled or Disabled. Disabled provides a faster boot and reduces the possibility of damaging the heads.
PS/2 Mouse Support	When this option is set to <i>Enabled</i> , BIOS supports a PS/2-type mouse.
Password Check	<p>This option specifies the type of BIOS password protection that is implemented. The settings are:</p> <p>Setup: The password prompt appears only when an end user attempts to run WinBIOS Setup.</p> <p>Always: A password prompt appears every time the computer is powered on or rebooted.</p> <p>The BIOS password does not have to be enabled. The end user sets the password by choosing the Password icon on the WinBIOS Setup screen.</p>
Boot to OS/2 Over 64MB	You need to set this option to Enabled when using the OS/2 operating system with installed DRAM which is greater than 64MB.
System BIOS Cacheable	BIOS always copies the system BIOS from ROM to RAM for faster execution. Set this option to <i>Enabled</i> to permit the contents of the F0000h RAM memory segment to be written to and read from cache memory.
C000, 16K Shadow; C400, 16K Shadow; C800, 16K Shadow; CC00, 16K Shadow; D000, 16K Shadow; D400, 16K Shadow; D800, 16K Shadow; DC00, 16K Shadow	<p>Disabled: The specified ROM is not copied to RAM.</p> <p>Enabled: The contents of the ROM area are not only copied from ROM to RAM for faster execution, the contents of the RAM area can be written to or read from cache memory.</p> <p>Cached: The contents of the ROM area are copied from ROM to RAM for faster execution.</p>

Advanced Chipset Setup

Choose the item from the BIOS Setup main menu. All Chipset Setup options are then displayed and are described in the following section:

AMIBIOS SETUP - ADVANCED CHIPSET SETUP (C)1998 American Megatrends, Inc. All Rights Reserved			
Trend ChipAway Virus	Enabled	16bit I/O Recovery Time	1 Sysclk
***** SDRAM Timing ***		PCI 2.1 Support	Disabled
Configure SDRAM by SPD	Disabled	USB Function	Enabled
RAS# to CAS# Delay	3 SCLKs	USB Legacy Support	Disabled
RAS# Precharge	3 SCLKs		
CAS# Latency	3 SCLKs		
Leadoff Cmd Timing	Auto		
***** EDO Timing ***			
Auto Configure EDO	Disabled		
EDO RASx Wait State	1 W/S		
EDO CASx Wait State	1 W/S		
DRAM Integrity Mode	Non-ECC		
DRAM Refresh Rate	15.6 us		
Memory Hole	Disabled		
VGA Frame Buffer USWC	Disabled		
PCI Frame Buffer USWC	Disabled		
USWC Write Post	Disabled		
Graphics Aperture Size	64MB		
Search for MDA Resources	Yes		
8bit I/O Recovery Time	1 Sysclk		

ESC : Quit	↑ ↓ → ← : Select Item
F1 : Help	PU/PD/+/- : Modify
F5 : Old Values (Shift)	F2 : Color
F6 : Load BIOS Defaults	
F7 : Load Setup Defaults	

- Trend ChipAway Virus** Choose *Enabled* to activate the Trend ChipAwayVirus function.

- Configure SDRAM Timing by SPD** Choose *Enabled* to set SDRAM timing by PC SDRAM SPD (Serial Presence Detect).

- RAS# to CAS# Delay** Set this option to select the proper delay time of SDRAM RAS# to CAS#.

- RAS# Precharge** Set this option to select the proper SDRAM RAS# precharge time.

- CAS# Latency** This option is designed to select the SDRAM CAS# Latency.

- Leadoff Cmd Timing** Set this option to select the proper SDRAM Leadoff timing.

- Auto Configure EDO** This option allows you to auto configure EDO settings when is set to *Enabled*.

EDO RASx, CASx Wait State	These two options are designed to select the proper Wait State for EDO RASx, and CASx, and these options only support the 66MHz-base system.
DRAM Integrity Mode	Choose Non-ECC, EC-Only, or ECC. Non-ECC: Has byte-wise write capability but no provision for protecting data integrity in the DRAM array. EC-Only: Data errors are detected but not corrected. ECC: Allows a detection between single-bit and multiple-bit errors and recovery of single-bit errors.
DRAM Refresh Rate	Set this option to select the proper DRAM refresh rate.
Memory Hole	Set this option to <i>Enabled</i> the memory hole.
VGA Frame Buffer USWC	Set this option to <i>Enabled</i> USWC for VGA frame buffer.
PCI Frame Buffer USWC	Set this option to <i>Enabled</i> USWC for PCI frame buffer.
USWC Write Post	Set this option to <i>Enabled</i> USWC Write can be post from PCI.
Graphics Aperture Size	Set this option to select the memory-mapped. Graphics data structures can reside in the Graphics Aperture. Use the default setting.
Search for MDA Resources	Set this option to <i>Enabled</i> to search for MDA resources.
8, 16 bit I/O Recovery Time	Set these options to specify the length of a delay inserted between consecutive 8-bit or 16-bit I/O operations.
PCI 2.1 Support	Set this option to <i>Enabled</i> to support the PCI v2.1 specification.

USB Function

Set this option to enable the system BIOS USB (Universal serial Bus) functions.

USB Legacy Support

Choose Enabled or Disabled. Set this option to enable the passive release on the USB (Universal Serial Bus).

Power Management Setup

Choosing the item from BIOS Setup main menu.

AMIBIOS SETUP - POWER MANAGEMENT SETUP (C)1998 American Megatrends, Inc. All Rights Reserved			
ACPI Aware O/S	No	Restore on AC/Power Loss	Last State
Power Management/APM	Enabled	K/B Resume From OFF	Disabled
Monitor Power State	Stand By	Mouse Resume From OFF	Disabled
Video Power Down	Disabled	Ring Resume From OFF	Disabled
Hard Disk Power Down	Suspend	LAN Resume From OFF	Disabled
Standby Timeout (Minute)	Disabled	RTC Alarm From OFF	Disabled
Throttle Clock Ratio	50-62.5%	RTC Alarm Date	15
Modem Use IO Port	N/A	RTC Alarm Hour	12
Modem Use IRQ	N/A	RTC Alarm Minute	30
Serial port 1	Monitor	RTC Alarm Second	30
Serial port 2	Monitor		
Paralle port	Ignore		
Primary master IDE	Monitor		
Primary slave IDE	Ignore		
Secondary master IDE	Monitor		
Secondary master IDE	Ignore		
System Thermal	Ignore	ESC : Quit	↑↓→←: Select Item
Thermal Slow Clock Raio	50-62.5%	F1 : Help	PU/PD/+/- : Modify
CPU Critical Temperature	60°C/149°F	F5 : Old Values (Shift)	F2 : Color
Power Button Function	On/Off	F6 : Load BIOS Defaults	
		F7 : Load Setup Defaults	

ACPI Aware O/S Set this option to Yes to enable the ACPI OS.

Power Management/APM Set this option to enable power management features and APM (Advanced Power Management).

Monitor Power State This option specifies the power state that the green PC-compliant video monitor enters when AMIBIOS places it in a power savings state after the specified period of display inactivity has expired.

Video Power Down This option specifies the power conserving state that the VESA VGA video subsystem enters after the specified period of display inactivity has expired.

Hard Disk Power Down	This option specifies the power conserving state that the hard disk drive enters after the specified period of hard drive inactivity has expired.
Standby Time out (Minute)	This option specified the length of system inactivity while in Full power on state. When this length of time expires, the computer enters Standby power state.
Throttle Clock Ratio	Set this option to specify the ratio of the system clock while in standby state.
Modem Use IO Port; Modem Use IRQ	Set these two options to specify IO port/IRQ number for modem device.
Serial Port 1; Serial Port 2; Parallel Port; Primary master IDE; Primary slave IDE; Secondary master IDE; Secondary slave IDE; System Thermal	When set to Yes, these options enable event monitoring on the specified hardware interrupt request line and the computer is in a power saving state, BIOS watches for activity on the specified IRQ line. The computer enters the full on power state if any activity occurs.
Thermal Slow Clock Ratio	Set this option to specify the ratio of system clock when CPU over the Critical Termerature.
CPU Critical Temperature	Set this option to specify critical temperature for CPU.
Power Button Function	Set this option to specify the operation of Soft-Off by the Power Button.
Restore on Ac/Power Loss	Set this option to specify system power state when AC power loss then come back.

K/B Resume From OFF; Mouse Resume From OFF; Ring Resume From OFF; LAN Resume From OFF	Set these options to enable the signals of Keyboard/Mouse/Modem Ring/LAN to wake up the system from the Soft-Off.
RTC Resume From OFF	Set this option to enable the RTC Alarm to wake up the system which is Soft Off.
RTC Alarm Date; RTC Alarm Hour; RTC Alarm Minute; RTC Alarm Second	Set these options to specify the RTC Alarm time on Date/Hour/Minute/Second.

PCI/Plug and Play Setup

Choose the item from the BIOS Setup main menu.

AMIBIOS SETUP - PCI / PLUG AND PLAY SETUP (C)1998 American Megatrends, Inc. All Rights Reserved			
Plug and Play Aware O/S	Yes	IRQ11	PCI/PnP
Clear NVRAM	NO	IRQ14	PCI/PnP
Sound Pro Chip Support	Enabled	IRQ15	PCI/PnP
Primary Graphics Adapter	PCI	Reserved Memory Size	Disabled
PCI VGA Palette Snoop	Disabled	Reserved Memory Address	C8000
OffBoard PCI IDE Card	Auto		
IDE Primary IRQ			
IDE Secondary IRQ	Disabled		
DMA Channel 0	PnP		
DMA Channel 1	PnP		
DMA Channel 3	PnP		
DMA Channel 5	PnP		
DMA Channel 6	PnP		
DMA Channel 7	PnP		
IRQ3	PCI/PnP		
IRQ4	PCI/PnP		
IRQ5	PCI/PnP	ESC : Quit	↑ ↓ → ← : Select Item
IRQ7	PCI/PnP	F1 : Help	PU/PD/+/- : Modify
IRQ9	PCI/PnP	F5 : Old Values (Shift)	F2 : Color
IRQ10	PCI/PnP	F6 : Load BIOS Defaults	
		F7 : Load Setup Defaults	

Plug and Play Aware OS Set this option to *Yes* if the operation system in this computer is aware of and follows the Plug and Play specification. Currently, only Windows 95 is PnP-aware.

Clear NVRAM Set this option to *Yes* to clear NVRAM.

Sound Pro Chip Support Set this option to *Enabled* to activate the onboard Sound Pro functions.

Primary Graphics Adapter Set this option to select AGP or PCI VGA for primary graphics adapter.

PCI VGA Palette Snoop When this option is set to *Enabled*, multiple VGA devices operating on different buses can handle data from the CPU on each set of palette registers on every video device. Bit 5 of the command register in the PCI device configuration space is the VGA Palette Snoop bit.

OffBoard PCI IDE Card	This option specifies if an offboard PCI IDE controller adapter card is installed in the computer. You must specify the PCI expansion slot on the motherboard where the offboard PCI IDE controller is installed. If an offboard PCI IDE controller is used, the onboard IDE controller is automatically disabled. If an offboard PCI IDE controller adapter card is installed in the computer, you must also set the Offboard PCI IDE Primary IRQ and Offboard PCI IDE Secondary IRQ options.
IDE Primary IRQ; IDE Secondary IRQ	These options specify the PCI interrupt used by the Primary (or secondary) IDE channel on the offboard PCI IDE controller.
DMA Channel 0, 1, 3, 5, 6, 7	These options specify the bus that the specified DMA channel is used on.
IRQ3, 4, 5, 7, 9, 10, 11, 14, 15	These options specify the bus that the specified IRQ line is used on. These options allow you to reserve IRQs for legacy ISA adapter cards.
Reserved Memory Size	This option is designed to be used for reserving memory for the IO card.
Reserved Memory Address	This option is designed to be used for reserving memory address for the IO card.

Peripheral Setup

Choose the item from the BIOS Setup main menu.

AMIBIOS SETUP - PERIPHERAL SETUP	
(C)1998 American Megatrends, Inc. All Rights Reserved	
OnBoard FDC	Auto
OnBoard Serial Port1	Auto
OnBoard Serial Port2	Auto
Serial Port2 Mode	Normal
IR Duplex Mode	Full
OnBoard Parallel Port	Auto
Parallel Mode	Normal
Parallel IRQ	Auto
Parallel DMA Channel	N/A
OnBoard IDE	Both
ESC : Quit ↑ ↓ → ← : Select Item F1 : Help PU/PD/+/- : Modify F5 : Old Values (Shift) F2 : Color F6 : Load BIOS Defaults F7 : Load Setup Defaults	

OnBoard FDC This option enables the FDC (Floppy Drive Controller) on the motherboard or auto detects the FDC.

OnBoard Serial Port1 This option specifies the base I/O port address of serial port 1.

OnBoard Serial Port2 This option specifies the base I/O port address of serial port 2.

Serial Port2 Mode This option specifies the serial port2 mode.
 Normal: The normal serial port mode is being used.
 IrDA/ASKIR: The serial port2 will be redirected to support IR function when this option is set to IrDA or ASKIR.

IR Duplex Mode This option is to specify the Duplex mode of Serial Port 2.

OnBoard Parallel Port Channel This option specifies the base I/O port address of the parallel port on the motherboard.

-
- Parallel Port Mode** Depends on the type of your external device which connects to this port to choose Normal, EPP, or ECP mode.
- Parallel Port IRQ** This option specifies IRQ to parallel port.
- Parallel Port DMA** This option is only available if the setting of the Parallel Port Mode option is EPP/ECP.
- OnBoard IDE** This option specifies the channel used by the IDE controller on the motherboard.

CPU Plug and Play Setup

Choose this item from the BIOS Setup main menu.

AMIBIOS SETUP - CPU PLUG AND PLAY SETUP	
(C)1998 American Megatrends, Inc. All Rights Reserved	
CPU Plug & Play	Auto
CPU Frequency Selection	100 Mhz
CPU Speed Selection (Mhz)	300(100x3)
System Hardware Monitor	
Current CPU Temperature	33°C/91°F
Current System Temperature	43°C/109°F
Current Fan1 Speed	4210 RPM
Current Fan2 Speed	0 RPM
Vcc	5.0100 V
Vcc3	3.325 V
Vcore	2.052 V
+12V	12.166 V
ESC : Quit ↑ ↓ → ← : Select Item F1 : Help PU/PD/+/- : Modify F5 : Old Values (Shift) F2 : Color F6 : Load BIOS Defaults F7 : Load Setup Defaults	

CPU Plug & Play Set this option to *Auto*, then CPU will be able to detect external frequencies automatically; when it is set to *Manual*, then it allows the user to set CPU frequency and speed.

CPU Frequency Selection This option can be set to *Enabled* only when the previous option (CPU Plug & Play) is set to *Manual*. 66, 75, or 83MHz are for Celeron CPUs, and, 100, 103, or 112 MHz are for Deschute CPUs.

CPU Speed Selection (MHz) Select a correct CPU speed to match your CPU. The ratio includes 2, 2.5, 3, 3.5, 4, 4.5, 5, 5.5, 6, etc.

Current CPU, System Temperature; Current Fan1, Fan2 Speed; Vcc; Vcc3; Vcore ; +12V These options are displayed only to show the status of the system hardware.

Change Supervisor Password

This item lets you configure the system password which is required every time when the system boots up or an attempt is made to enter the Setup program. The password cannot be longer than six characters.

Note: Keep a safe record of the new password. If you forget or lose the password, the only way to access the system is to clear CMOS memory by holding down the <End> key then powering on to reboot the system.

Auto-Detect Hard Disks

If your system has an IDE hard drive, you can use this utility to detect its parameters and automatically enter them into the Standard CMOS Setup. This utility will autodetect up to four IDE devices.

Save Settings and Exit

Select this item to save the values entered during the current session and then exit the BIOS setup program.

Exit Without Saving

Select this item to exit the BIOS setup program without saving the values which has been entered during the current session.

Chapter 4

SoftWare Driver

The CD came with the package is free of charge and includes all our products' drivers and the path of this mainboard's drivers and utilities are listed below:

- ❑ IDE Driver for Windows 95
(CD-ROM): \IDE\M760\Win95\Setup.exe
- ❑ USB Driver for Windows 95
(CD-ROM): \USB\Eusbsupp\Usbsupp.exe;
(CD-ROM): \USB\Cusbsupp\Cusbsupp.exe for
Chinese Windows95
- ❑ VGA Driver Path
(CD-ROM): \VGA\3DProAGP\
- ❑ Sound Driver Path
(CD-ROM): \SOUND\SOUNDPOR\New\
- ❑ BIOS Update Utility Path
(CD-ROM): \UTILITY\
- ❑ Bundled PC-cillin Path
(CD-ROM): \PC-cillin\